

第 11 章 図表題名

- 表 11-1: Table 11-1 Bio-economic life table of *Amyntas* sp. (H-1) in area D 1972
- 表 11-2: Table 11-2 Bio-economic life table of *Amyntas* sp. (H-1) in clay sand area 1972
- ☒ 11-1: Fig. 11-1. Inter relation ship between environment and earthworm
- ☒ 11-2: Fig. 11-2. The components of eartbworms life system
- ☒ 11-3: Fig. 11-3. Inter relation ship between environment and animals.

Table 11-1 Bio-economic life table of *Amynthas* sp. (H-1) in area D 1972

Date	N	B	B.W	P	E	F.R A.H	F.R A.V	F.C A.H	F.C A.V	L-C	R.W	* m/m	* m	A
Jan.	0.0	0.0	0.0			0.0	0.0	0.0	0.0	1176.5				
Feb.14	60.8	379.6	6.2	15.8		0.2	0.0	0.1	0.0	1175.3		1.7	6.2	
Feb.23	83.2	619.2	7.4	26.6		0.4	0.0	0.3	0.0	1170.2		1.9	11.0	
Mar.12	92.8	933.7	10.1	18.5		0.6	0.1	0.4	0.1	1162.2		1.7	11.1	
Mar.28	108.8	1850.9	17.0	57.3		3.8	0.3	2.6	0.3	1118.7		1.5	11.0	
Apr.12	100.5	2457.3	24.5	51.9	11.5	5.9	0.5	4.1	0.5	1049.7		1.6	10.8	
Apr.27	99.8	4924.5	49.3	166.2	1.7	19.3	1.5	13.4	1.4	827.7		1.4	9.7	24.2
May 10	93.4	6821.0	73.0	152.5	26.1	30.7	3.1	21.4	2.8	531.3		1.3	8.6	14.9
May 23	88.3	7892.4	89.4	114.2	31.9	33.0	6.4	23.0	5.9	68.4		1.5	9.5	
Jun. 8	76.8	8378.2	109.1	101.7	71.3	32.8	5.1	22.9	4.7	0.0	15.2	1.3	7.1	4.9
Jun.19	68.0	8326.0	122.4	87.9	92.6	27.0	4.9	18.9	4.5		15.2	2.7	10.4	6.01(6.10)
Jun.30	66.6	7368.0	110.6		87.2	25.6	5.6	17.9	5.1		15.2	1.6	7.5	5.1
Jul.15	51.8	5028.5	97.1		156.0	19.3	8.6	13.4	7.9		15.2	1.5	5.9	9.9
Jul.29	26.2	1803.5	68.8		232.5	9.1	4.9	6.3	4.5		15.2	3.9	7.1	
Aug.28	0.0	0.0	0.0		60.1	0.0	0.0	0.0	0.0		15.2			

N:density ($N m^{-2}$), B:Biomass (dry wt m^{-2}), B.W:Body dry weight of individual, P:Production (dry wt w^{-2}), E:Elimination (dry wt w^{-2})

F.R A.H:Litter requirement of *Amynthas* sp.(H-1), F.R A.V:Litter requirement of *Amynthas vittatus*,

F.C A.H: Litter consumption of *Amynthas* sp. (H-1), F.C.A.V: Litter consumption of *Amynthas vittatus*

L-C:Litter supply - Litter consumption, R.W: Resource supply from wormcast, (m/m, m, A: The degree of Aggregation of individuals, see Chapter 8)

Table 11-2 Bio-economic life table of *Amynthas* sp. (H-1) in clay sand area 1972

Date	N	B	B.W	P	E	F.R	L-C	L	* m/m	* m
Feb. 2	94.4	370.1	3.9	12.3		0.0				
						0.0			1.2	6.7
Feb. 15	105.6	638.0	6.0	20.6		0.2			1.1	7.3
Mar. 22	97.6	1178.0	12.1	17.5	2.1	2.3			1.3	7.6
Apr. 16	74.7	1944.9	23.5	41.1	10.4	7.9	450.0	450.0	1.0	4.5
	(82.9)			68.6	0.0		405.7	402.0		
Apr. 29	91.2	2836.6	34.2			18.6			0.9	4.9
	(82.9)			102.9	76.4		278.8	358.0		
May 11	57.3	3154.3	51.3			26.3			1.3	4.6
	(61.5)			79.8	0.0		106.8	110.4		
May 26	65.7	4351.8	70.8			42.4			1.6	6.3
	(61.5)			38.4	45.0		0.0			
Jun. 15	49.7	4199.3	84.6			29.0			0.9	2.8
					68.3			69.4		
Jul. 7	38.4	2695.9	70.1			19.4			2.0	4.7
					128.4			0.0		
Jul. 28	0.0	0.0				0.0				

N: density ($N m^{-2}$), B: Biomass (dry wt m^{-2}), B.W: Body dry weight of individual, P: Production (dry wt w^{-2}), E: Elimination (dry wt w^{-2})
 F.R :Litter requirement of *Amynthas* sp.(H-1), L-C:Litter supply of the decaying strow bags - Litter consumption,
 L: The weight of the decaying strow bags, (m/m, m, A: The degree of Aggregation of individuals, see Chapter 10)

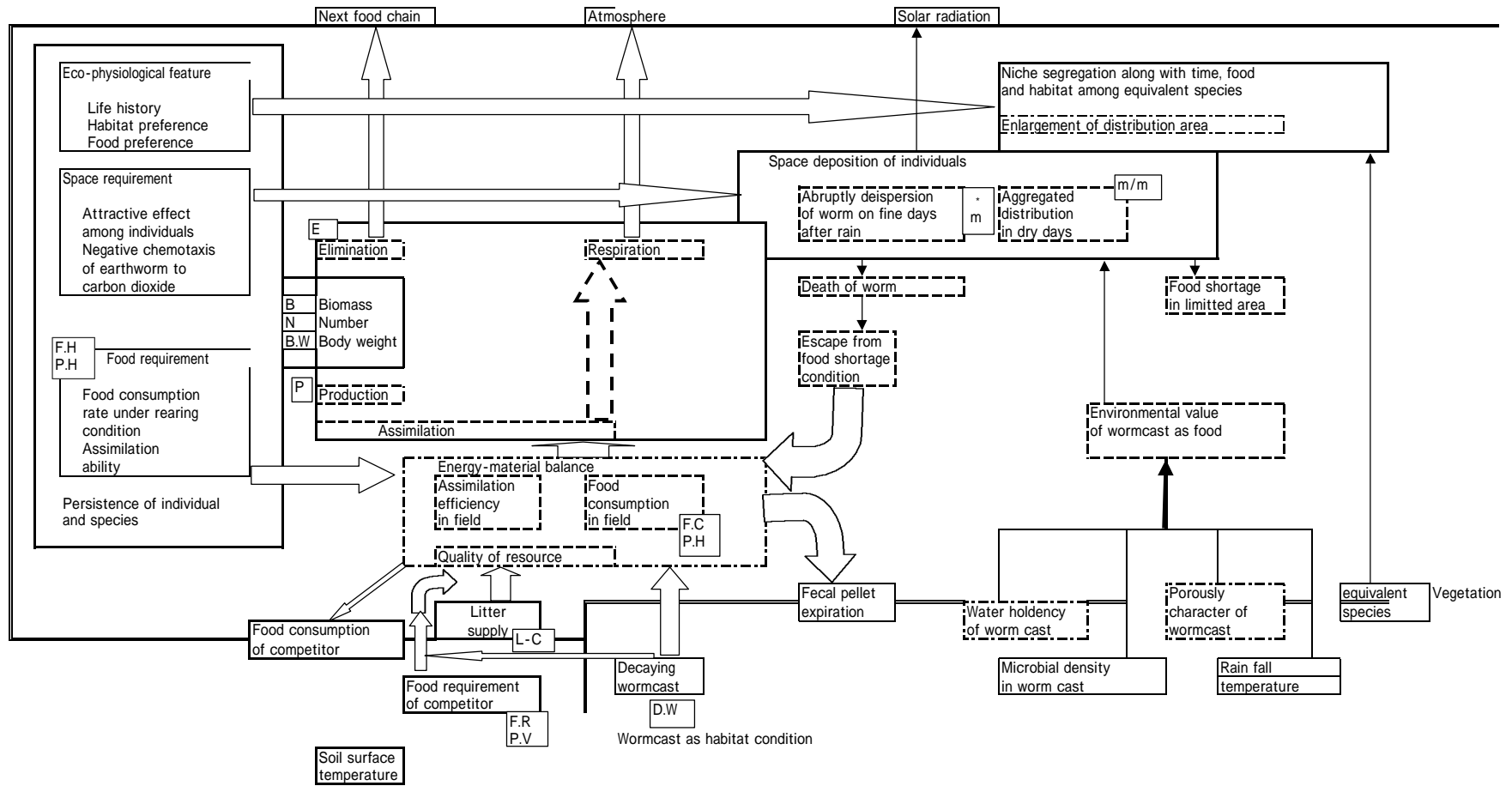

Fig. 11-1. Inter relationship between environment and earthworm

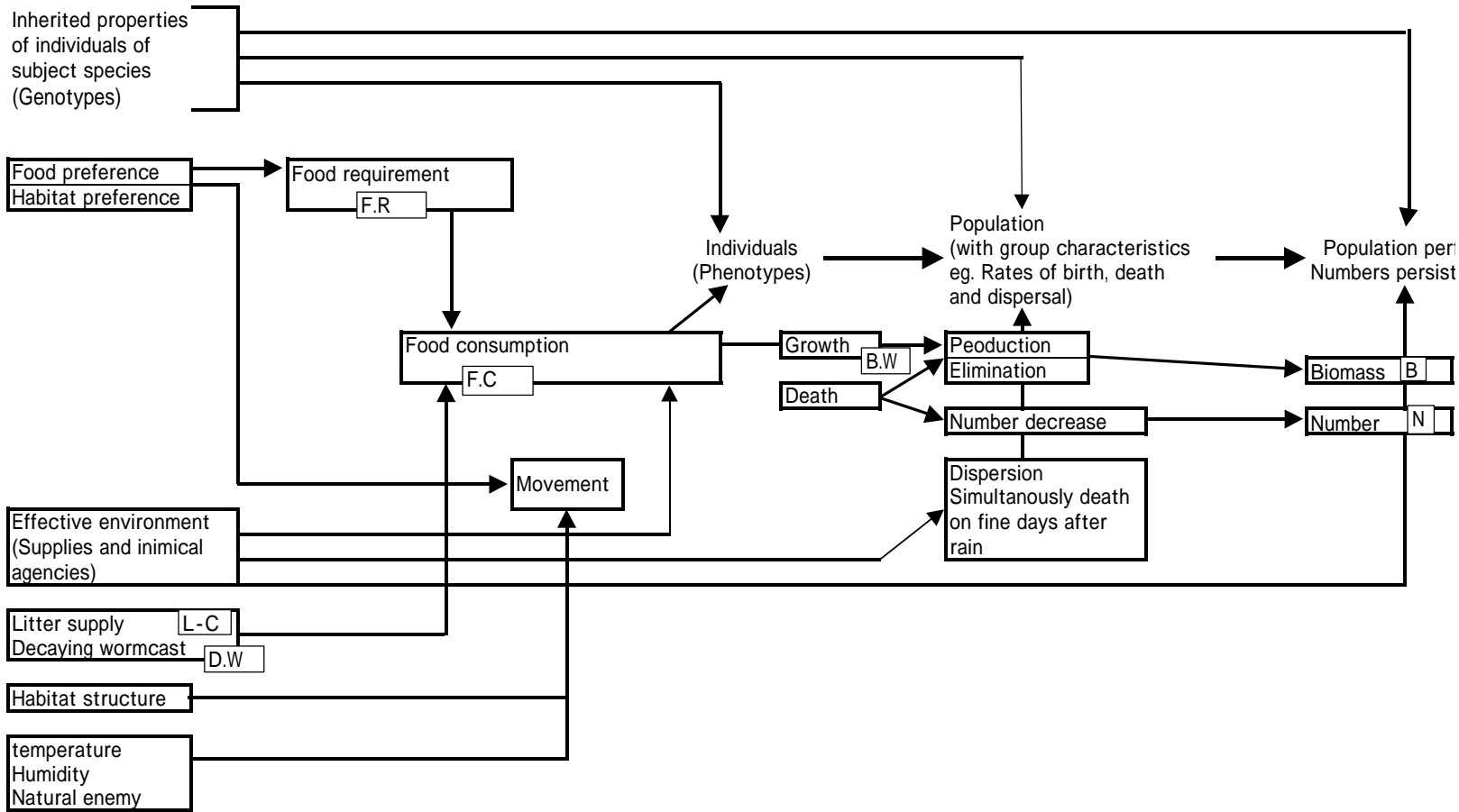

Fig. 11-2. The components of earthworms life system

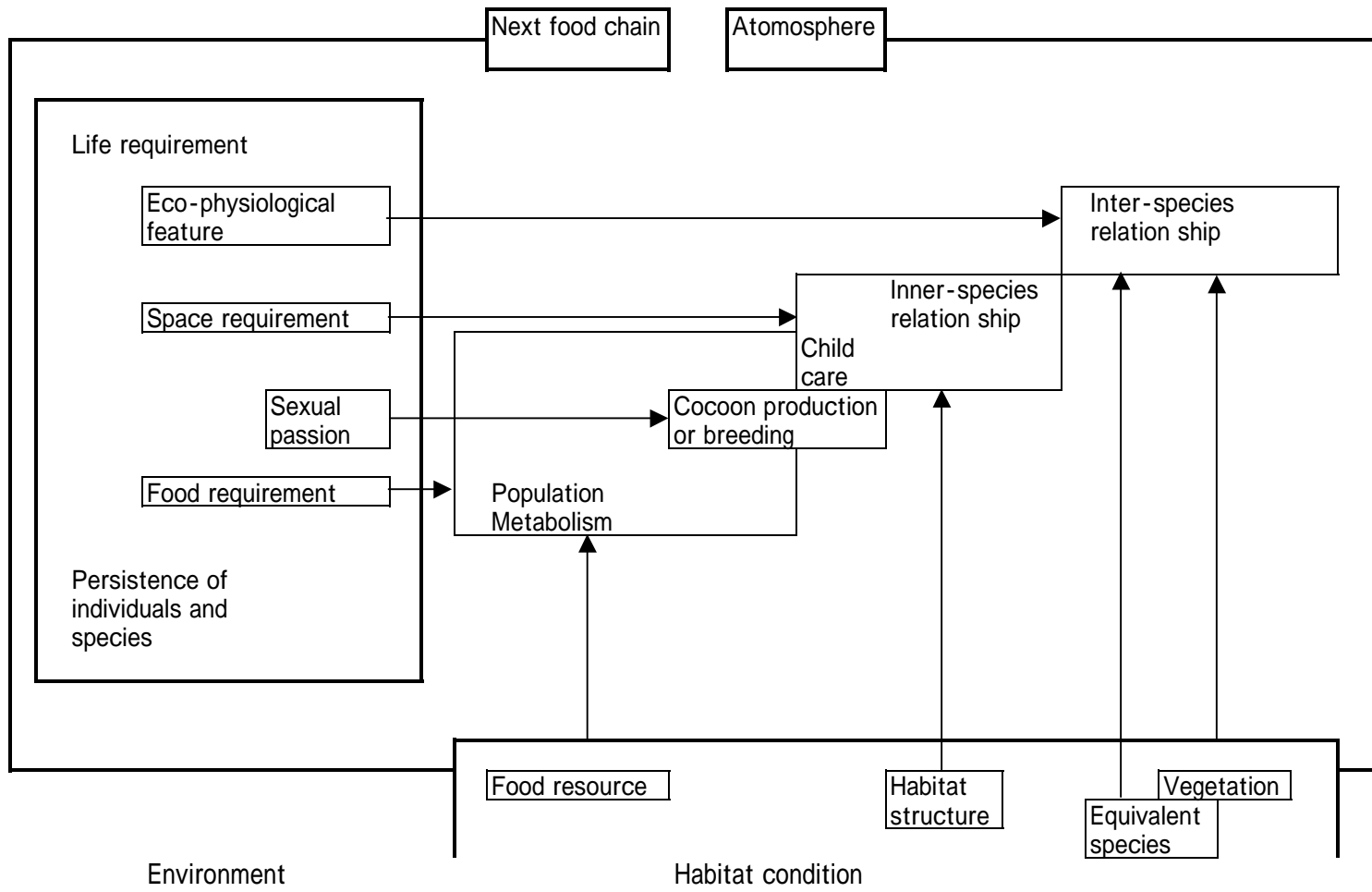

Fig. 11-3. Inter relationship between environment and animals.

Acknowledgement (of part one)

I am grateful to Prof. Y. Ono, the laboratory of Ecology, Faculty of Science, Kyushu University, for his invaluable suggestions. I am grateful also to Prof. T. Kikuchi, Amakusa Marine Biological Laboratory, Kyushu University, for his encouragement and advice. My special thanks are due to assistant Prof. M. Tanaka, Amakusa Marine Biological Laboratory, Kyushu University, for his encouragement and criticism during the course of this study. My thanks are due to Mr. S. Tanaka, the laboratory of Ecology, Faculty of Science, Kyushu University, for his advice on taxonomy of earthworms.

December 31, 1989

Yasuaki Sugi