

# Interaction of animal with its environment

## Contents

- 1 Introduction      The main course to discuss
- 2 Structure of earthworm community in the suburbs of Fukuoka City
  - Position of representative species *Pheretima* sp.(H-1) in earthworm community
  - 2-1 Maximum biomass of earthworm in various vegetation
  - 2-2 Eco-morphological feature of representative *Pheretima*
- 3 Description of representative species *Pheretima* sp.(H-1) population
  - 3-1 Description of study area and ecological distribution of *Pheretima* sp.(H-1) population
  - 3-2 Number of individuals and weight distribution of *Pheretima* sp.(H-1) population
  - 3-3 Population metabolism of Earthworm populations *Pheretima* sp. (H-1)
  - 3-4 Daily fecal pellet production rate, daily food ingestion rate digestive efficiency and assimilation efficiency
  - 3-5 the distribution pattern of individuals
    - 3-5-1 mass emergence of *Pheretima* sp. (H-1) on fine day after rain
    - 3-5-2 The structure of habitat and the distribution pattern of earthworm; *Pheretima* sp. (H-1).
- 4 Resource utilization and energy balance of Earthworm *Pheretima* sp. (Oligochaeta : Megascolecidae) in old grass field
- 5 The bio-economic life table of earthworm *Pheretima* sp.

## 1 Introduction

How is population density or biomass decided? It is the first theme in this paper. The second purpose is a discussion about the interaction of the animal and the environment. The interaction is a background for earthworm's biomass.

This thesis is composed of five parts roughly separately. First part is the structure of earthworm community in the suburbs of Fukuoka City. This group is composed by two subgroups a) Density, body weight of individual and maximum biomass of earthworm in various vegetation and b) Eco-morphological feature of representative *Pheretima*. Second group is the study on Population metabolism of Earthworm populations *Pheretima* sp. (H-1). Third group is the study on the daily fecal pellet production rate, daily food ingestion rate digestive efficiency and assimilation efficiency. Fourth group is the study on the distribution pattern of individuals. This group is composed by two subgroups a) Mass emergence of *Pheretima* sp. (H-1) on fine day after rain and b) The structure of habitat and the distribution pattern of earthworm. Fifth group is the study on the resource utilization and energy balance of Earthworm *Pheretima* sp. (Oligochaeta: Megascolecidae) in old grass field. And, a population ecology side and a bio-economics side of *Pheretima* sp. (H-1) was discussed from mutual viewpoints by using the bio-economic life table. Finally, the interaction of the animal and the environment is considered.

## 2 Structure of earthworm community in the suburbs of Fukuoka City

Position of representative species *Pheretima* sp.(H-1) in earthworm community

### 2-1 Maximum biomass of earthworm in various vegetation

Table 1-1 Distribution of environments under study

Table 1-3 Species composition and maximum biomass of earthworm in various vegetation

Figure Photograph and figure of representative species *Pheretima* sp. (H-1)

Kobayashi (1941) suggested that the number of species of terrestrial earthworms in Japan is about 190, but only 80 of them had been recorded. In present study, 10 species of *Pheretima* group and 4 species of Lumbricidae were collected. Most abundant species was *Pheretima s. schmardae*, *Pheretima* sp. (H-1), *Pheretima vittata*, *Pheretima irregularis*, *Pheretima* sp. (M-3), *Pheretima heterocheata* *Pheretima micronara*, *Allolobophora caliginosa* and *Allolobophora japonica*. Table 1-3 summarizes the maximum biomass of the representative species.

*Pheretima* sp. (H-1) was distributed in younger glass field (area G), old glass field (area D) and shrine forest (area H). It was most abundant in area D (123.0 g fresh wt m<sup>-2</sup>). The population in area G may be a part of the population in area D. *A. vittata* have the same distribution areas as *Pheretima* sp. (H-1), but was most abundant in area H (29.24 g fresh wt m<sup>-2</sup>).

1972 population of *Pheretima* sp.(H-1) in Area D is the main object in the following consideration.

## 2-2 Eco-morphological feature of representative *Pheretima*

Table 2-3 Eco-morphological feature of representative *Pheretima*

1) Ecological distribution of earthworm was investigated in the experimental field of the Department of biology Kyushu University, which was composed by two vegetation type. Litter dwellers: *Ph. schmardae*, *Pheretima* sp. (H-1), *Ph. vittata* distributed within the area having a plenty ground flora, thick A<sub>0</sub> horizon. On the other hand, Soil dwellers: *Ph. heterocheta* distributed in whole area, regardless vegetation type and habitat structure near soil surface.

2) Some eco-morphological feature such as body size, body form mobility and the developmental degree of intestinal coeca, and feeding habit were investigated on seven representative *Pheretima* species: *Ph. s. schmardae*, *Pheretima* sp. (H-1), *Ph. vittata*, *Ph. irregularis*, *Pheretima* sp. (M-3), *Ph. heterocheta* and *Ph. micronaria*.

3) Soil dweller: *Ph. heterocheta* and *Ph. micronaria* had in a small body size and slender body form, and showed a sluggish mobility compared with those of litter dwellers. Among litter dwellers, *M. schmardae* had the smallest body size, and *Pheretima* sp. (M-3) had the slenderest body form. It was discussed that the eco-morphological feature of each species were largely reflected on their life history, their hibernating behavior and distributions, in relation to the structure of their habitats.

4) There was large difference between every species in the gut material. The main component of gut material were large particle of raw humus in *A. vittata*, of small particle of raw humus in *Pheretima* sp. (H-1), of small particle of raw humus and organic rich material in *A. irregularis*, of organic rich material in *M. schmardae* and *Pheretima* sp. (M-3), and or organic rich soil and mineral material in *A. micronarius* and *Ph. heterocheta*. There were observed a linear relation between the decayed degree of gut material and the developmental degree of intestinal coeca, of each species. The feeding habit of each species was discussed in relation to the quantity and quality of the food resource presenting in their habitats.

5) It was discussed that *Pheretima* species found in suburb of Fukuoka city had a different niche with each other, along three axes: life history, habitat preference and food preference. The genera of *Pheretima* in Japan lack the well-developed calciferous gland. However, this problem is unsettled.

### 3 Description of representative species *Pheretima* sp. (H-1) population

#### 3-1 Description of study area and ecological distribution of *Pheretima* sp.(H-1) population

Fig. 2-1. The vegetation maps of the experimental field

Fig. 2-3a. Distribution maps of earthworm in the experimental field

Figure 2-1 shows the flora maps in the experimental field. A part of the experimental field (area D) was covered densely by the dicotyledon, The remained part of the experimental field (area G)

was covered with the monocotyledon. In the soil of Area D, the organic was rich, the ratio of fine particle was high and the density was low. The A<sub>0</sub> horizon in area D was thick. On the other hand, in the soil of area G, the organic material was poor, the ratio of coarse sand was high and the soil density was high. The A<sub>0</sub> horizon in area G was thin. The net production of above ground vegetation was estimated by the summation of each species maximum standing crop. The estimated primary production was 1176.5 g (dry wt) m<sup>-2</sup>. The standing crop in area G on July 1972 was 251.2 g m<sup>-2</sup>. That in area D on same day was 549 g m<sup>-2</sup>. Then, the net primary production in area G seems to be less than half of that in area D.

There were drawn a map (1/300 scale) of the experimental field showing the distribution of earthworm species (Fig. 2-3 a,b). The distribution of *Pheretima* sp. (H-1) which is the litter dweller is corresponding to the distribution of the dicotyledon and the distribution of *A. vittata* and *M. schmardae* were restricted within the area D, the soil surface of which were covered with the dicotyledon. *Ph. heterocheta* was scattered over the experimental field regardless of vegetation type. As mentioned, the area covered by the dicotyledon (area D) had plenty ground flora and thick A<sub>0</sub> horizon, and the area covered by monocotyledon (area G) had not. These results may mean that *Pheretima* sp. (H-1), *Ph. vittata* and *Ph. schmardae* require a plenty flora and thick A<sub>0</sub> horizon for their distribution, and *Ph. heterocheta* can live in either condition. *Pheretima* sp.(H-1) and *Ph. vittata*: This two species live in the litter layer of same vegetation. This two species show a similar food habit. Then, in the discussion about the resource use for *Pheretima* sp.(H-1), *Ph. vittata* is considered to be main Food competitor of the former species.

### 3-2 Number of individuals and weight distribution of *Pheretima* sp.(H-1) population

Fig. 1-10. Seasonal change in population density of earthworms in area D.

Fig.1-11b. Seasonal change in body weight frequency of earthworms in area D for the period Feb. 1972 to

Small earthworms were collected on Feb. 14, 1972. It is shown that a new generation appeared (Fig. 1-10). Its density was 60.8 m<sup>-2</sup>. The weight of individual on Feb. 14 was 38-100 mg fresh wt (Fig. 1-11). Afterwards, the densities increased, and it reached the highest density of 108.8 m<sup>-2</sup> on March 28. The density decreased slowly in the period from March 28 to May 23, 1972. The density decreased rapidly from May 28 to August 28 except between June 19 and June 30. The clitellum appears on the body surface of all individuals collected after June 30. This shows that most individuals of *Pheretima* sp. (H-1) reached maturity by the end of June. The earthworms collected on June 19 showed the maximum weight of 1019-2589 mg fresh wt. Copulation was frequently observed on rainy days of June and early July 1972. After word, the weight decreased slightly and was 552-1431 mg fresh wt on July 29. All earthworms disappeared by late August.

### 3-3 Population metabolism of Earthworm populations *Pheretima* sp. (H-1)

Fig. 3-1. CO<sub>2</sub> expiration rate of *Pheretima* sp. (H-1)

Fig. 3-4. Seasonal change in biomass, respiration, average body weight and number of *Pheretima* sp. (H-1)

in area D 1972

At that time in 1970, the bio-economics formed one flow in ecology. The evolution ecology appears, and the bio-economics has disappeared almost after 1980. There are respect of work and respect of consumption in the bio-economics. This paragraph discusses consumption. Consumption is a total of production and breath of the animal body. The production of *Pheretima* sp.(H-1) is calculated from the number of individuals and the average weight shown in the foregoing paragraph. However, it is necessary to measure the amount of the respiration.

Figure 3-1 shows the respiration rate of *Pheretima* sp. (H-1). The CO<sub>2</sub> expiration rate can be represented as follow

$$\text{CO}_2 \text{ h}^{-1} = 111.23 \text{ W}^{0.69271} \quad \text{at } 25 \text{ } ^\circ\text{C} \quad (3-1)$$

$$\text{CO}_2 \text{ h}^{-1} = 76.50 \text{ W}^{0.69296} \quad \text{at } 20 \text{ } ^\circ\text{C} \quad (3-2)$$

$$\text{CO}_2 \text{ h}^{-1} = 58.50 \text{ W}^{0.73654} \quad \text{at } 15 \text{ } ^\circ\text{C} \quad (3-3)$$

W is the weight of the earthworms in g fresh wt.

#### ***Pheretima* sp. (H-1) in area D 1972:**

The biomass of *Pheretima* sp. (H-1) in area D 1972 increased after Feb., reached a maximum level on May 23. This highest level has been maintained for the period of the rainy season (Fig. 3-4). The maximum biomass was 8.378 g dry wt m<sup>-2</sup> (177.067 KJ m<sup>-2</sup>) on June 8, 1972. The average biomass was 4.368 g dry wt m<sup>-2</sup> (92.299 KJ m<sup>-2</sup>). The production was estimated at 11.489 g dry wt m<sup>-2</sup> (242.672 KJ m<sup>-2</sup>). The density of cocoon was 128.6 m<sup>-2</sup> and the average weight of cocoon was 18.97 mg fresh wt. These mean 8.648 KJ m<sup>-2</sup> of cocoon production. The respiration rate increased after Feb., reached a maximum level on June 19 and maintained the level for June. The maximum rate of respiration was 6.510 KJ m<sup>-2</sup> d<sup>-1</sup> on June 30, 1972. Total respiration was calculated as 589.275 KJ m<sup>-2</sup>.

The assimilation (P+R) of *Pheretima* sp. (H-1) 831.917 KJ m<sup>-2</sup> in area D 1972

When the resource use process is considered by the following paragraph, this value is an important value.

Respiration ratio (R/A) and turn over rate ( P/B ), these are key word in bio-economics. What were these ratios? The bio-economics has disappeared before clarified of the content of these ratios.

#### **3-4 Daily fecal pellet production rate, daily food ingestion rate digestive efficiency and assimilation efficiency**

- Fig.4-3. Daily fecal pellet production rate and daily food ingestion rate of the worms cultured at 15
- Fig.4-6. Nutrient contents of the materials in alimental canal of the pre-mature worms collected in field
- Table 4 - 2 Comparison of some metabolic rate of two *Pheretima* species between field and culture
- Fig. 5-2a. The relation between the assimilation efficiency and the ratio of food consumed to total material consumed.
- Table 5-1 Assimilation efficiency of *Pheretima* sp. (H-1)

1) *Pheretima* sp. (H-1) were cultivated under three temperature condition, and fecal pellet production, food consumption rate growth rate were determined.

2) The cultivated earthworms required 34 - 64 days for their maturation against to 100 days of maturation period for the field earthworms. Also, the maximum weight of the cultivated earthworms was attained to 4 - 4.5 g fresh wt against 1.7 - 2.5 g fresh wt of the field earthworm.

3) Fecal pellet production of the cultivated earthworms were 1054 - 1540 mg dry wt for an individuals having one gram body wet weight.

4) Litter consumption of the cultivated earthworms were 374 - 590 mg dry wt for an individuals having one gram body wet weight. Still, the litter consumption rate of mature earthworms was smaller than the rate of immature earthworms.

5) The quality of the material consumed by the field earthworms were investigated with determining Carbon and Nitrogen content in the gut content of the field earthworms. The carbon content in material was regarded as the more fundamental indicator for the consideration on the metabolic rate of field earthworms. Carbon content in the gut content of the field earthworm was 72.15 mg g<sup>-1</sup> dry wt in average. On the other hand, Carbon content in the materials consumed by the cultivated earthworm was estimated at 89.91 mg g<sup>-1</sup> dry wt. From these results, it was estimated that the food consumption of the field earthworm was attained to 73.64 % of the rate of the cultivated earthworms.

The carbon content in gut material of the field individuals was 72.15 mg g<sup>-1</sup> dry wt in *Pheretima* sp. (H-1) and 116.83 mg g<sup>-1</sup> dry wt in *Ph. vittata*. These were equivalent to 77.03 % in *Pheretima* sp. (H-1), and 91.71 % in *Ph. vittata*, of the estimated carbon contents of the cultivated earthworms, respectively. The litter feeding ratio of the *Pheretima* sp. (H-1) field populations can be presumed from the data of the content of the carbon of the field population by the next expression.

$$72.125 \text{ C mg} = 222.93 \text{ C mg } X + 22.51 \text{ C mg } (1 - X)$$

$$X = 0.2477$$

Where the value 222.93 mg is the carbon content of the food used for cultivation, and the value 22.51 mg, the carbon content of the soil used. This calculation mean that *Pheretima* sp. (H-1) in area D 1972 consume the food at 24.77 %. The ratio of the food consumed to total material consumed by the cultivated individuals having the same weight frequency of the area D 1972 population was estimated as 35.5 %. Namely, the true rate of the food resource consumption of the field earthworms is 69.78 % of the rate of the cultivated earthworms.

Then, the litter consumption rate of immature earthworms fed on newly litter should be expressed as follow

$$Y' = 428.27 W^{0.6040} \quad \text{at } 25^\circ\text{C} \quad (4-10')$$

$$Y' = 380.75 W^{0.6957} \quad \text{at } 20^\circ\text{C} \quad (4-11')$$

$$Y' = 254.58 W^{0.9749} \quad \text{at } 15^\circ\text{C} \quad (4-12')$$

Also, the litter consumption rate of mature earthworms fed on newly litter should be expressed as follow

$$Y' = 295.89 W^{0.4382} \quad \text{at } 25^{\circ}\text{C} \quad (4-16')$$

$$Y' = 248.83 W^{0.5283} \quad \text{at } 20^{\circ}\text{C} \quad (4-17')$$

$$Y' = 161.82 W^{0.8359} \quad \text{at } 15^{\circ}\text{C} \quad (4-18')$$

6) It was thought that the lower growth rate and the lower weight of the field earthworms than those of the cultivated earthworms might be due to the lower resource consumption rate of the field earthworm than that of the cultivated earthworms. These results explained the low growth rate, the smaller weight and the weight losses after maturation, of the field individuals. Dividing the limited food resource among members and between competitors might cause the decrease of the food resource consumption rate of *Pheretima* sp. (H-1) in field. Against this, there were no food shortage, no food competitor and no food conditioning under the cultivation.

### 3-5 the distribution pattern of individuals

#### 3-5-1 Mass emergence of *Pheretima* sp. (H-1) on fine day after rain

Fig. 7-3. Daily change in number of observed dead individuals.

Fig. 7-4 Daily fluctuation of CO<sub>2</sub> evolution.

Fig. 7-6. The relation in soil respiration rate between the worm cast and the soil litter mixture

Fig. 7-2 Schema of the response box

Fig. 7-7a Number of earthworm showing the rushing out behavior to various concentration of Carbon dioxide gases

Fig. 7-9 Population meaning of the simultaneously death of earthworm;

The daily change of the number of death earthworms that had died on the bare ground was shown in Figure 7-3

1) The observation on mass emergence of *Pheretima* sp. (H-1) were carried out on the bare land in the experimental field of Department of Biology Kyushu University in the period from May to July for two years 1971 and 1972. The mass emergence of *Pheretima* sp. (H-1) occurred frequently on fine day after rain. Several individuals was killed by solar radiation on bare land. Few individuals died on other days.

2) The response of *Pheretima* sp. (H-1) to harmful gases was examined under experimental condition. Earthworm showed the abruptly creeping out behavior even to the small increase of CO<sub>2</sub> tension. They showed no behavior response by the continuously exposing of pure Nitrogen gas.

3) The soil respiration rate on fine day after rain was two fold of the rate on rainy days or dry days. The increase of soil respiration rate in soil air on fine days after rain was the factor inducing the creeping our behavior of earthworm.

4) Bacteria increased to 3-5 fold during the passage of materials through the intestine of

*Pheretima* sp. (H-1). It was inferred that the wormcast had more plentiful flora of microbial population than the control soil.

5) Worm cast showed higher soil respiration rate and larger water holding capacity than those of control materials. The higher respiration rate of wormcast might be due to the high microbial activity besides the high water holding capacity of the materials. The warm and wet condition on fine days after rain stimulated the activity of microbial populations contained in wormcast and then the soil respiration rate increased.

6) CO<sub>2</sub> expiration rate was higher in wormcast (earthworm's habitat) than in other areas. By the reason that earthworm piled up the pellets on soil surface most abundantly in early summer, soil respiration in earthworm's habitat might be highest in this season through a year. This might be the reason why mass emergence of earthworm occurred only in this season.

7) Earthworm adjusted their density to the adaptive density by the dispersion of individuals on fine days after rain. As the biological conditioning of the earthworm's habitat caused the mass emergence of earthworm, the mass emergence of earthworm on fine days after rain was regarded as the self regulation.

### **3-5-2 The structure of habitat and the distribution pattern of earthworm**

Fig. 8-2. Seasonal change in the distribution pattern of individuals of field population.

Fig. 8-3. The relation ship between number of individual and thickness of wormcast.

Fig. 8-8. The structure of habitat and the distribution pattern of earthworm; *Pheretima* sp. (H-1).

The life history of earthworm *Pheretima* sp. (H-1) can be distinguished to four developmental stages in relation to the distribution pattern of individuals and the structure of their habitat.

#### **Ecological meaning of wormcast relating to the life history of earthworm**

The significance of wormcast for earthworm can be summarized in three, 1) Good habitat through a life span of animal except fine days after rain, 2) Bad habitat on fine days after rain and 3) Food resource. Good habitats of wormcast for animal depend on their the moisture retentivity and of the porosity character of wormcast. In the porositic wormcast layer, earthworms can move easily and escape from drying or solar radiation easily. Wormcast became to be bad habitat for earthworms on fine days after rain, which induce an abruptly dispersion of animals. Bad habitat of wormcast depend on the high density of microbial population contained in cast material (Chapter 7). The role of wormcast as food resource was brought by the decaying part of wormcast. Earthworm show a different behavior to each character of wormcast, each of which appear under a given weather condition. The linear regressions shown in Fig. 8-3 express the integrated evaluation of earthworm to various character of wormcast. The reciprocal value of the slope in equation (1/A) represent the number of individuals per one cm thickness of wormcast below the depth of B cm from soil surface.

(c) The decaying wormcast become to the alternatively food resource or earthworm.

5) The value of 1/A inducing from the linear equations between the number of individuals and

thickness of wormcast was regarded as the integrated evaluation of earthworm to wormcast as shelter and food resource.

The life history of earthworm *Pheretima* sp. (H-1) can be distinguished to four developmental stages in relation to the distribution pattern of individuals and the structure of their habitat. Figure 8-7 shows the life history of *Pheretima* sp. (H-1) relating to their distribution pattern. Also, Figure 8-8 summarizes the life history of earthworms relating to the habitat structure.

#### **Four developmental stages in relation to the distribution pattern of individuals and the structure of their habitat**

The spatial distribution passes a highly aggregated phase in spring. Through the dispersed phase in later spring, the second aggregated phase followed in late spring-early summer. When the wetter season come, earthworms dispersed abruptly. After wetter season, earthworm distributed in patch.

Young 1 stage: When a new individual of *Pheretima* sp. (H-1) gives birth at the early spring, these individuals forms the contagious distribution. This distribution pattern may be caused by the aggregately distribution of the cocoons (Fig. 2-3b, in chapter 2). The degree of aggregation reduced in the period from late Feb. to early May (Fig. 8-2). in early spring young individuals dispersed with the slow pace for searching newly food, remaining the posterior part of their bodies in the wormcast site (Fig. 8-2 and Fig. 8-4).

Young 2 stage in dry season: Dry days occur, frequently, in the period from late May to middle June. Water content of soil near surface might be low with the reason of no rain and of relatively high temperature in these periods. Earthworm might move from thin wormcast to thick wormcast to avoid drying in dry days. New comer might pile up the large quantity of fecal pellets on the thick wormcast. Then, the thick wormcast might enlarge the water holding capacity. Where, earthworm comes to endure a drier situation. However, earthworm is exposed to heavier food shortage in these conditions.

Matured stage: Clitellum appeared on the body surface of earthworms after June, showing that earthworms reached maturity in June. The abruptly dispersion (the mass emergence) of earthworm accompanying the death of individuals occurred frequently on fine days after rain in June and July (Chapter 7). The individuals confirming aggregated phase in dry days of late May might be under severe food shortage. The decrease of density after the mass emergence of earthworm means the mitigation of food shortage for earthworm. Copulation was frequently observed on rainy days of June and early July 1972.

Post matured stage; The population density decreased with the end of wetter summer. Earthworm begun to form aggregated phase to avoid drying again. The aggregated distribution of matured

earthworms after dry summer may relate to the aggregated distribution of earthworm's cocoon. It may induce the aggregated phase of young earthworms in early spring of next year.

#### **4 Resource utilization and energy balance of Earthworm *Pheretima* sp. (Oligochaeta : Megascolecidae) in old grass field**

The number, the biomass, the metabolism and the distribution pattern of *Pheretima* sp. (H-1) (Oligochaeta: Megascolecidae) in grass field was studied in previous chapters. Three process of the resource utilization of *Pheretima* sp. (H-1) through a life span can be estimated by using the results, which has been shown in previous chapters. First estimation is the feeding process that animal demonstrates his own food demand in field. Secondary estimation is the feeding process that animal divides the resource which exists in field with companions. Third process is obtained by synthesizing the result concerning the quantity and quality of the resource consumed by the population.

##### **1. First estimation of the resource utilization**

The food requirement of *Pheretima* sp. (H-1) in area D 1972 was presumed 2963.66 g dry wt m<sup>-2</sup> of litter (Chapter 4). Otherwise, the amount of fecal pellet produced by this population was presumed to be 13247.09 g dry wt m<sup>-2</sup> (Chapter 4). Then, the total energy quantity of the resource consumed was estimated as 62416.494 KJ m<sup>-2</sup> (2963.66 × 17.983 + 10283.43 × 0.887). The average assimilation efficiency of cultivated earthworms was 8.124 % (Chapter 5). These values mean that the population of *Pheretima* sp. (H-1) in area D 1972 would absorb 5070.715 KJ m<sup>-2</sup>. This estimated value is amount to 609.32 % of the energy consumption of A=P+R (832.198 KJ m<sup>-2</sup>) (Chapter 3).

##### **2. Secondary estimation of the resource utilization**

The second guess process is an amount of the energy supply from the environment. It is synonymous with the amount of energy which animal can use. Some preparations are necessary for this estimation. Figure 9-1 shows the procedure of secondary estimation. The content of each items in the figure are represented as follow

(a) The different vegetation area (area G) adjoined study area (area D). *Pheretima* sp. (H-1) distributed mainly in area D but rarely in area G (chapter 2). The estimation of the available energy was made on the population distributed within area D.

b) Annual net production of the above ground vegetation in area D 1972 has been presumed to be 1176.45 g dry wt m<sup>-2</sup> (Chapter 1).

(c) The maximum thickness 1.834 cm of the wormcast was equivalent to 7441 g dry wt m<sup>-2</sup> (Chapter 8).

(d) This means that earthworm blend 1176 g dry wt of litter fall with 6264 g dry wt of soil. Then, wormcast contained litter at a ratio of 15.81 %. The value of 15.81 % of the litter to total weight

was equivalent to 25.088 % of the food used for cultivation to total weight consumed.

(e) total quantity of fecal pellet produced by two litter dwellers: *Pheretima* sp. (H-1) and *Ph. vittata* (Goto et hatai) were amount to 13247.09 g dry wt m<sup>-2</sup> and 1766.5 g dry wt m<sup>-2</sup>, respectively (Chapter 4).

(f) The maximum thickness 1.834 cm of the wormcast was equivalent to 7441 g dry wt m<sup>-2</sup> (Chapter 8). Its turn over rate was given by the ratio of the pellet production of earthworms to the maximum quantity of wormcast. The rate was estimated at 2.0177. This value mean that soils and litter passed twice per a year through the earthworm intestine.

(g) The amount of the fecal pellet production of two primary litter feeders in area D 1972, is presumed like 13247.09 g dry wt m<sup>-2</sup> as for *Pheretima* sp. (H-1) and 1766.5g dry wt m<sup>-2</sup> as for *Pheretima vittata* (chapter 4). These figures mean, 11.766 % among all food resource was divided for *Ph. vittata* and 88.234 % was divided for *Pheretima* sp. (H-1). After these preparations, the amount of energy which the earthworm can absorb from these materials is presumed as follows. Then, the available energy of *Pheretima* sp. (H-1) could be estimated as 490.365 (26713.459 × 0.88234 × 0.02080) in first pass and 479.905 {(26713.459 × 0.88234 - 490.365) × 0.02080} in second pass, and 8.326 {(26713.459 × 0.88234 - 490.365 - 479.905) × 0.02080 × 0.0177} in third pass. This calculation means that *Pheretima* sp. (H-1) could absorb 978.638 KJ m<sup>-2</sup> in total.

### 3. Third estimation of the resource utilization

Third feeding process was estimated basing on the nutrient contents of the gut materials of earthworms. The nutrient analysis showed that earthworms ingested litter at 15.61 % (Chapter 4). The field population of *Pheretima* sp. (H-1) in area D 1972 eject 13247.09 g dry wt of fecal pellet (Chapter 4). This means that the field population consumed 2067.71 g dry wt litter and 11179.38 g dry wt of soil. The energy equivalent of litter was 17.983 (Golley 1963) and that of soils 0.887 KJ g<sup>-1</sup> (chapter 4). The assimilation efficiency of the earthworms in field was 1.895 % (Chapter 5). Then, the absorbed energy was calculated as 892.531 KJ {(2067.71 × 17.983 + 11179.38 × 0.887) × 0.01895}. This value exceeds only 7.25 % than the energy consumption for respiration and production.

If population requires resource as the cultivated earthworm (First estimation), the required energy would attain to 6.08 times of the energy consumption (A=P+R). The weight of field earthworms was smaller than that of the cultivated earthworms. The weight of the field earthworms decreased after maturation. Otherwise, the cultivated earthworms gained the more weight growth after maturation. The difference in the growth pattern between field and cultivation mean that first estimation did not reflect the true process of the resource utilization of the population in field.

The absorbable energy (second estimation) exceeds 17.6 % than the energy consumption

( $A=P+R$ ). The absorbed energy (third estimation) exceeds only 7.25 % of the energy consumption of field population ( $A=P+R$ ). Then, the second and third process on feeding activity of earthworm population may reflect the true process of the resource utilization in field. This mean that the assumption in the second estimation and the third estimation were reasonable. Namely, animals share the available resource from litter and other thing with members and the available resource pass through the earthworm intestine more than twice per a year.

## **5 The bio-economic life table of earthworm *Pheretima* sp.**

### **-The interaction between animal and environment-**

How is population density or biomass decided? The fundamental factors deciding population density or biomass may be the quantity and the quality of food resource. In Chapter 9, the resource utilization process and the energy balance of *Pheretima* sp. (H-1) (Oligochaeta: Megascolecidae) population in area D 1972 were studied. The population density and the presence of food competitor besides the quantity and quality of food resource influenced on the resource utilization process and the energy balance of earthworm. Also, the resource utilization process might relate to the space deposition of individuals and the mortality of the population. Namely, the earthworm divides the resource with the companion of the same species or another species, in field condition. These results show that the population study and the bio-economics must be thought from mutual viewpoints.

Morisita (1973) proposed a bio-economic life table basing on new concept. A bio-economic life table contained production, elimination, food consumption and respiration besides survivor ship rate and mortality rate. Morisita said, the table had a possibility that population study and bio-economic study could be thought from mutual viewpoints.

The purpose in this chapter is the following. Using the bio-economic life table, which Morishita (1973) advocated, a population ecology side and a bio-economics side of *Pheretima* sp. (H-1) was discussed from mutual viewpoints.

### **1. The bio-economic life table of *Pheretima* sp. (H-1)**

Some new bio-economic items were added to the bio-economic life table for earthworm. New bio-economic items were food requirement, food consumption, food requirement of competitor, food consumption of competitor and resource supply. The bio-economic life table of earthworm may be available for the study on the resource utilization process of population. Table 11-1 shows the bio-economic life table for the population of *Pheretima* sp. (H-1) in area D 1972. The main food competitor of *Pheretima* sp. (H-1) in area D was *Pheretima vittata* (Goto et Hatai). The content of the added new item in this table is as follows.

- a) The intrinsic food requirement of population, b) The intrinsic food requirement of food competitor, c) The litter consumption of the field population, d) The litter consumption of field population of food competitor, e) Litter supply, f) Alternatively food resource from the decaying wormcast,
- g) Some additional items

The quantity of wormcast, the degree of the aggregation ( $m$ ,  $m/m$ , and  $1/A$ ) were studied in earlier chapters. These composed a portion of the bio-economic life table. The population abundance or biomass may relate to the aggregation pattern of individuals and the nature of habitat as shelter for animals (chapter 8). Then, the bio-economic life table gets a further possibility for the mutual consideration between population study and bio-economic study.

## 2. The relation among each items

In hitherto sections the relation among each item composing the bio-economic life table was interpreted. The bio-economical faces and the population faces, of *Pheretima* sp. (H-1) can be summarized in a figure with the viewpoint of the reciprocal relation ship between animal and environment. Figure 11-1 shows these relations. The thick letters in the figure show each item composing the bio-economic life table. The fundamental component in the figure consists of three groups of items. The left part in the figure shows the items related to the intrinsic life requirement of animals. The items related to the intrinsic life requirements are consisting of three sub groups: food requirement, habitat requirement and physiological tolerance. Biomass may mean the size of requirement. Also, development stage may mean the quality of requirement because the change of content of requirement with aging.

The lower part in the figure shows the environment surrounding animals. The projecting items from the environment show the habitat condition, which have the relation to the intrinsic life requirement of animal.

The center part in the figure shows the consequence of the reciprocal relation between animal and environment. Namely, the consequence of reciprocal relation is the real life of a population developed in field. The lines in the figure show the basically relation ship between items.

In the relation ship between animal and environment, animal is the subject, and environment is the background for life of animal. Animal recognizes the resource relating to their life requirement from environment by his sensory organs and act on its resource. As for expressing the animal production, animal detect food from environment with his sensory organ, take this material in their intestine and produce animal tissue. Where, production is the outcome of the reciprocal relation between animal and environment. As animal tissue is animal themselves, production connected with the items of life requirement. It is shown in a thick line in the figure.

The animal tissue produced appears as the change of life requirement.

Animal live in environment, doubtless as like a part of ecosystem. But they have a boundary between itself and environment. The inside of the body have owns structure being different from that of environment. Animal is not subordinate to environment, but act upon environment by his requirement. The animal is not an automatic machine though the animal acts according to his rule. They alter it, and provide environment with a steady structure (assimilation of animal). The subjectivity of animal in the energy and material balance was interpreted in earlier. The subjectivity of animal in interaction can be seen also in the improvement of habitat condition. The wormcast produced by earthworm became to good habitat for them under a certain weather condition (chapter 7 and 8). Namely, earthworms alter resource into the wormcast providing the shelter for earthworm.

Clark et al (1967) said

"The effective environment consists of inimical agencies, which oppose the survival and reproduction of individuals of the subject species, besides the resource (supplies of all kinds) required for population maintenance such as living space, food and favorable physio-chemical conditions."

However, animal tolerates the inimical agencies such as high temperature with their migrating behavior. For example, in dry days of May, earthworms move to thicker wormcast to avoid drying. Also, on fine days after rain, some individuals escape from thicker wormcast with the decrease in the value of the environmental values of habitat as shelter (chapter 7-8).

If the schema shown in figure 11-1 is renewed along the conception of life system, the relations in figure 11-1 may be rewritten as figure 11-2.

Thus, the contents of the items and the relations in Figure 11-1 were very different to those of Life system advocated by Clark et al (1967). My purpose to make the figure 11-1 is to obtain the comprehensive description about the life of individuals-species. Where, the number of individuals or the biomasses are merely one face of the life of individuals-species. Naturally, animal live in environment and, rightly, the number of any population are determined within an ecosystem. However, the inner site of animal bodies is distinguished with his body wall from the environment. Various sides of the life of the animal: Bio-economics and inner-species relation ship, etc. are expressions with a different life of a certain animal's individual-species. Animal (individuals - species) live according to owns life requirement, being relatively independent of the principle of its environment. Then, it was necessary to suppose the independence of animal in the mutual interaction between animal and environment.

The approach of Life system i) express a full appreciation of the fact that a population and its environment are complementary elements in a system, and interact in the ecological events and process which are involved in the determination of population number: and ii) links the study

of specific populations with the study of communities and hence ecology with evolution (Clark et al 1967).

Otherwise, The schema shown in figure 11-3 may be useful as a guide for the understanding of life of individuals-species in environment, where various faces of life of individuals-species (such as bio-economics, population change and inner species relation ship) were concerned in the mutual relations of each faces.

**Table 1-1 Distribution of environments under study**

	Area G	Area D	Area H	Area K
Tree vegetation			<i>Celtis sinensis</i> <i>Ciianomomum Camphora</i> <i>Ginkgo biloba</i>	<i>Quercus glauca</i> <i>Shiia Sieboldii</i> <i>Ilex integra</i>
Cover degree			ca 40 %	100%
Ground surface vegetation	<i>Imperata cylindrica</i> <i>Carex spp.</i> <i>Cyperus rotundus</i>	<i>Solidago altissima</i> <i>Vicia hirsuta</i> <i>Artemisia vulgaris</i>	<i>Artemisia vulgaris</i> <i>Achyranthes japonica</i> <i>Erigeron annuus</i>	<i>Damnacanthus indicus</i> <i>Trachelosperum asiaticum</i> <i>Pleiolblastus variegatus</i>
Cover degree	ca 50 %	100%	ca 70 %	ca 20 %
Litter layer (cm)	0	0.1 - 1.5	2.0 - 4.0	3.5 - 5.0
A <sub>0</sub> horizon (cm)	1.7 - 4.2 (av. 3.4)	3.0 -12.3 (av.6.6)	5.0 -40.0 (av.14.0)	5.0 -10.0 (av. 6.0)
Ignition loss weight (%)	4.0 -13.6 (av. 6.1)	3.8 -13.8 (av.7.6)	7.4 - 9.5 (av. 8.5)	10.2-11.0 (av.10.6)
Soil density (g dry wt cm <sup>-3</sup> )	1.0 - 2.1 (av. 1.5)	0.4 - 1.5 (av.0.9)	0.7 - 0.8 (av. 0.76)	0.6 - 0.7 (av. 0.65)
Soil particle less than 1 mm (%)	42.7 -61.0 (av.50.8)	46.0 -88.0 (av.64.7)	73.12	28.21
pH in H <sub>2</sub> O	5.56	6.05	6.2	4.7
Primary production (g dry wt m <sup>-2</sup> )	540. ?	1176.5	1010 ?	844

**Table 1-3 Species composition and maximum biomass of earthworm in various vegetation**

Area	g fresh wt m <sup>-2</sup> (g dry wt m <sup>-2</sup> )				
	Area G	Area D	Area H	Area K	IBP Minamata
Species					
<i>Pheretima schmardae</i>		6.648 (0.472)	1.877 (0.146)		
<i>Pheretima sp. (H-1)</i>	11.045 (0.760)	122.964 (8.378)	43.945 (2.982)		
<i>Pheretima vittata</i>	0.679 (0.047)	24.912 (1.694)	29.24 (1.964)		
<i>Pheretima irregularis</i>				10.552 (0.725)	
<i>Pheretima sieboldi</i>					2.312 (0.157)
<i>Pheretima sp. (M-3)</i>					17.122 (1.153)
<i>Pheretima heterochaeta</i>	60.512 (4.246)	34.39 (2.454)		3.762 (0.262)	
<i>Pheretima micronaria</i>			5.111 (0.364)	0.471 (0.054)	2.809 (0.142)
<i>Allolobophora caliginosa</i>	7.298 (0.490)	11.14 (0.785)			
<i>Allolobophora jaoinica</i>			0.182 (0.022)	2.494 (0.189)	
Other fewer species	<i>Pheretima hupeiensis</i>	<i>Pheretima hupeiensis</i>			Four unknown Pheretima
	Two unknown Pheretima	Two unknown Pheretima			One unknown Lumbricidae
	<i>Bimastos parvus</i>	<i>Bimastos parvus</i>	<i>Bimastos parvus</i>	<i>Bimastos parvus</i>	

Table 2-2 body length, body width and body weight of representative Pheretima

Species	n	Body length (mm)	body width (mm)	Body weight (mg dry wt)	length/width ratio
<i>Pheretima schmaridae</i>	89	63.2 ± 10.2	3.0 ± 0.4	473.5 ± 168.7	21.1
<i>Pheretima sp. (H-1)</i>	542	93.8 ± 16.8	4.9 ± 0.7	1922.0 ± 800.3	19.1
<i>Pheretima vittata</i>	65	125.7 ± 22.4	7.5 ± 1.0	5006.1 ± 2227.5	16.8
<i>Pheretima irregularis</i>	30	104.1 ± 20.4	5.0 ± 0.7	2205.9 ± 1008.3	20.8
<i>Pheretima sp. (M-3)</i>	29	109.4 ± 15.4	4.0 ± 0.4	1433.5 ± 394.3	27.4
<i>Pheretima heterochaeta</i>	755	101.9 ± 27.1	2.9 ± 0.7	799.3 ± 333.9	35.1
<i>Pheretima micronaria</i>	53	72.3 ± 14.5	3.1 ± 0.5	563.8 ± 195.5	23.3

Table 2-3 Eco-morphological feature of representative Pheretima

Species	<i>Pheretima schmaridae</i>	<i>Pheretima sp. (H-1)</i>	<i>Pheretima vittata</i>	<i>Pheretima irregularis</i>	<i>Pheretima sieboldi</i>	<i>Pheretima sp. (M-3)</i>	<i>Pheretima heterochaeta</i>	<i>Pheretima micronaria</i>
Life history	Newly born hatch out in spring, mature in summer and disappear till August .		Newly born hatch out in spring, mature in June and some remained till November.		Newly born hatch out in summer, mature till next summer, and disappear till August.		Many younger appear in summer, mature till next summer, and some remain till winter.	
Life time	6 months		8 months		12 months		over 12 months	
Age composition	One generation				Two or three generation			
Main habitat	Compost	Old grass field	Old grass edge of	Edge of forest	Ever green forest in mountain site		Younger vegetation	Older vegetation
Inhabit layer	Litter				Litter - A -Soil			
Hibernate site					Dry dingle	Deeper soil layer		
Body pigmentation	yellow green	dark reddish brown	dark brown with yellow band	dark reddish brown	deep black purple		light grey brown	light purplish brown
Number of pair of spermatoca	two				three	two	four	
Activity	Active						sluggish	
Body form	Plumply						slenderly	
Body size	474	1922	6006	2206	30500	1434	799	564
Intestinal coeca	5	6-7	8	6	Most complex	Simple showing a conical form		
Composition of gut content	Organic rich matter	Small raw humus	Large raw humus	Organic rich matter with small raw humus	Litter from tree leaves	Organic rich matter	Organic rich soil and mineral soil	

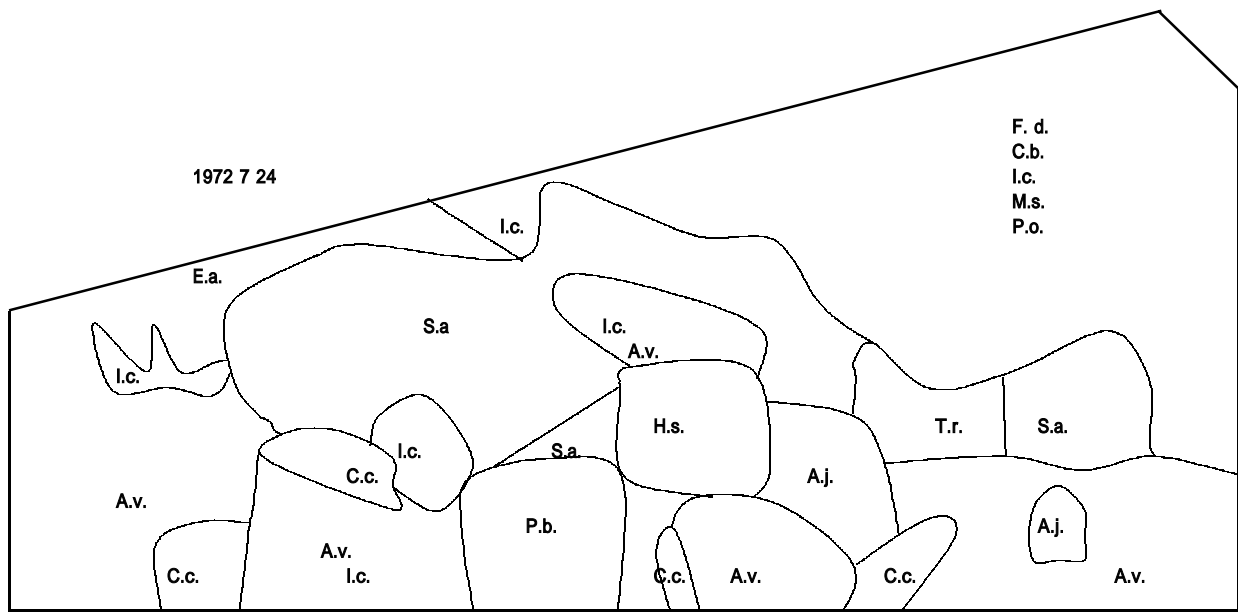

- |                                      |                                   |  |                                   |
|--------------------------------------|-----------------------------------|--|-----------------------------------|
| A.j. : <i>Achyranthes japonica</i>   | A.v. : <i>Artemisia vulgaris</i>  | C.b. : <i>Cyperus brevifolius</i>        | C.c. : <i>Comelia communis</i>    |
| F.d. : <i>Fimbristylis dichotoma</i> | G.A. : <i>Galium Aparine</i>      | H.s. : <i>Hydrocotyle sibthorpioides</i> | I.c. : <i>Imperata cylindrica</i> |
| M.d. : <i>Medicago denticulata</i>   | M.s. : <i>Miscanthus sinensis</i> | P.B. : <i>Polygonum Blumei</i>           | P.o. : <i>Paspalum orbiculare</i> |
| S.a. : <i>Solidago altissima</i>     | S.m. : <i>Stellaria media</i>     | S.o. : <i>Sonchus olreaceus</i>          | T.r. : <i>Tradescant reflexa</i>  |
| V.h. : <i>Vicia hirsuta</i>          | E.a. : <i>Arigeron annuus</i>     |  |                                   |

9m

1972 7 15

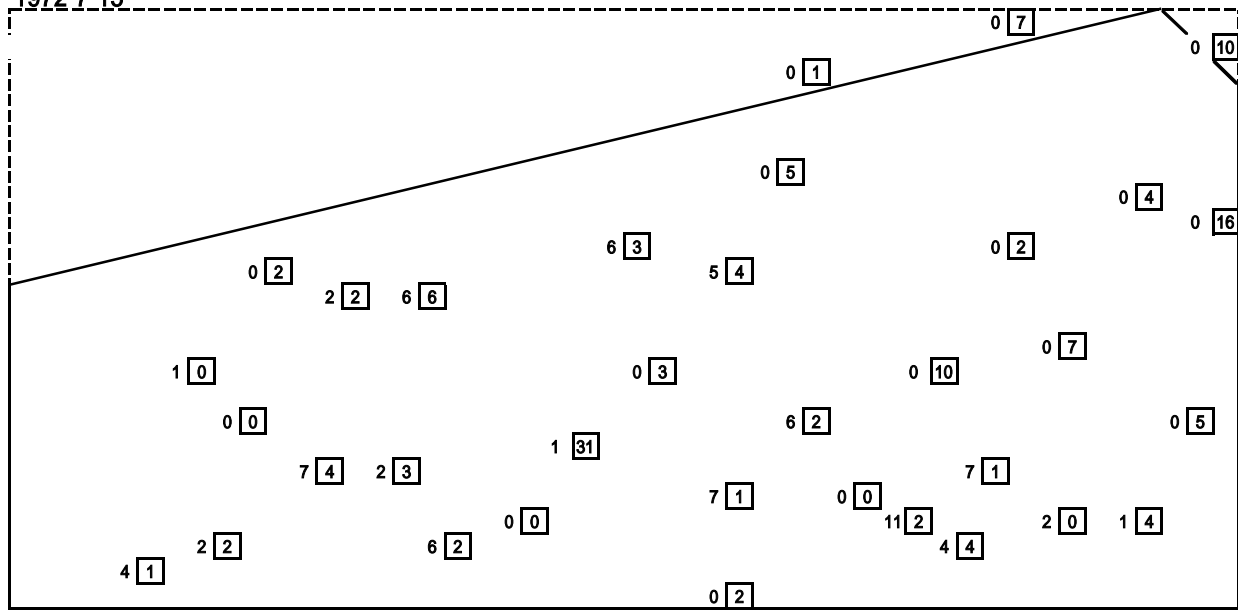

9m

Black letter indicate the density of *Pheretima* sp. (H-1) and Black letter in rectangular indicate the density of *Pheretima heterochaeta*. (25 x 25 cm<sup>-2</sup>)

Fig. 2-3. Distribution maps of vegetations and of earthworms in the experimental field.

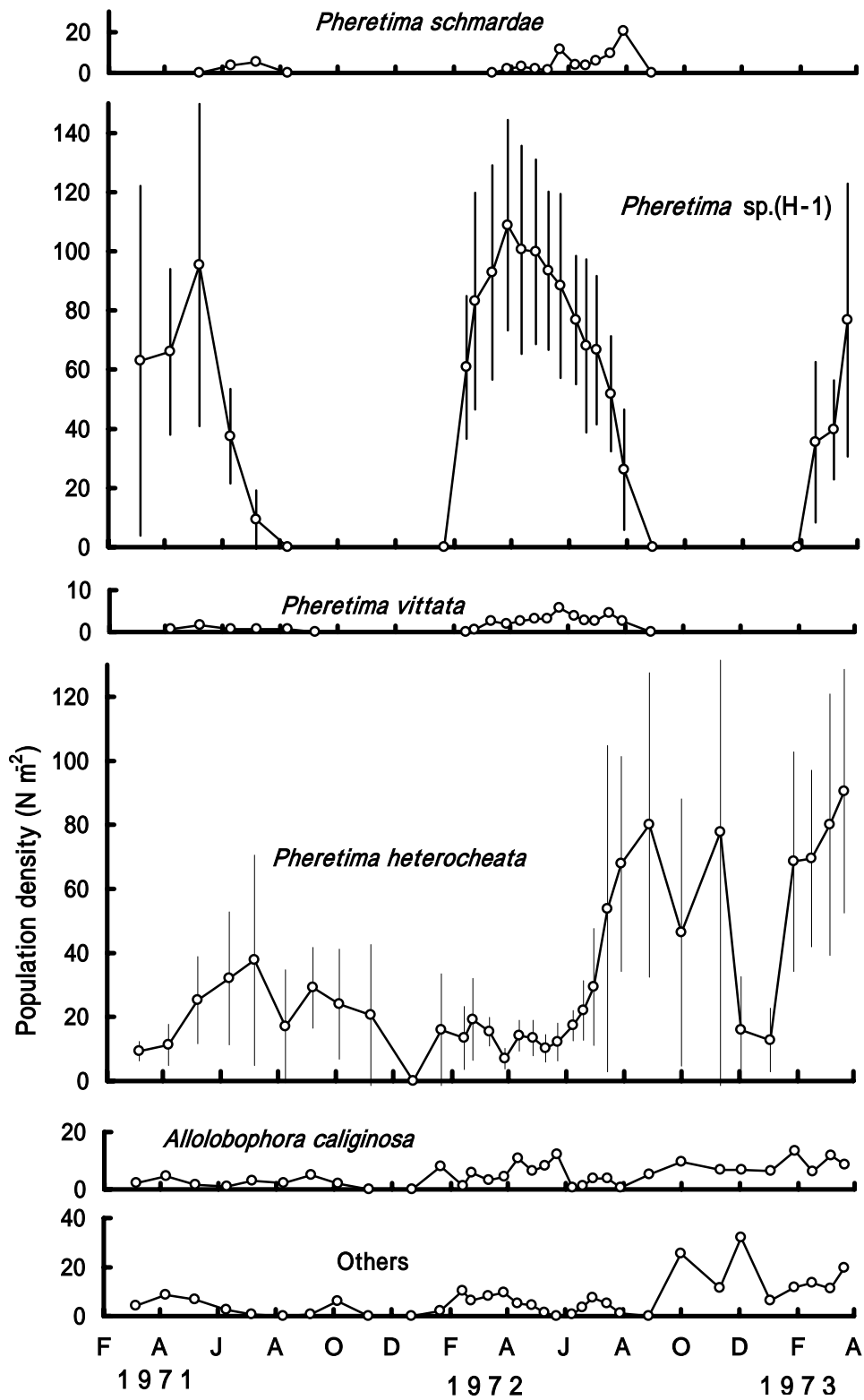

Fig. 1-10. Seasonal change in population density of earthworms in area D. Vertical lines indicate one standard deviation.

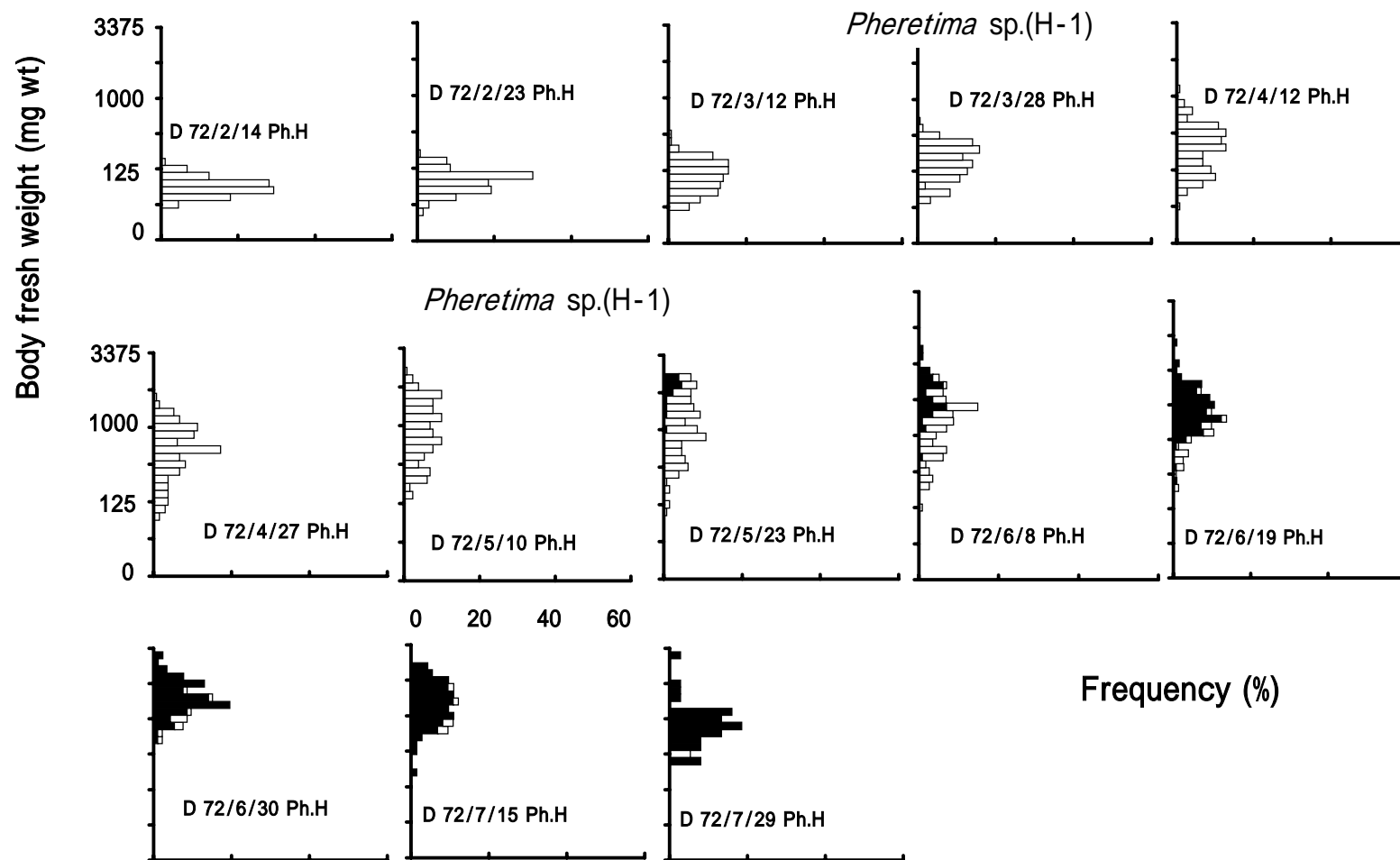

Fig. 1-11c. Seasonal change in body weight frequency of earthworms in area D for the period late May to late July 1972.

Open bars indicate the frequency of immature and black bars indicate the frequency of mature.

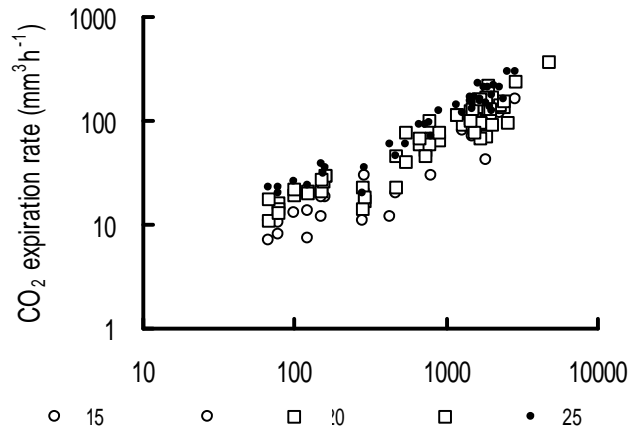

Fig. 3-1. CO<sub>2</sub> expiration rate of *Pheretima* sp. (H-1).

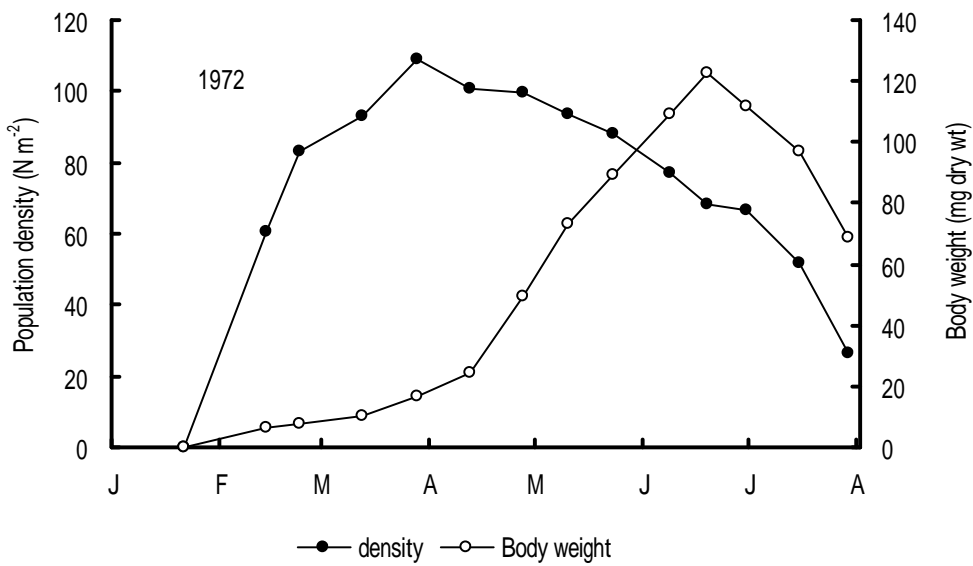
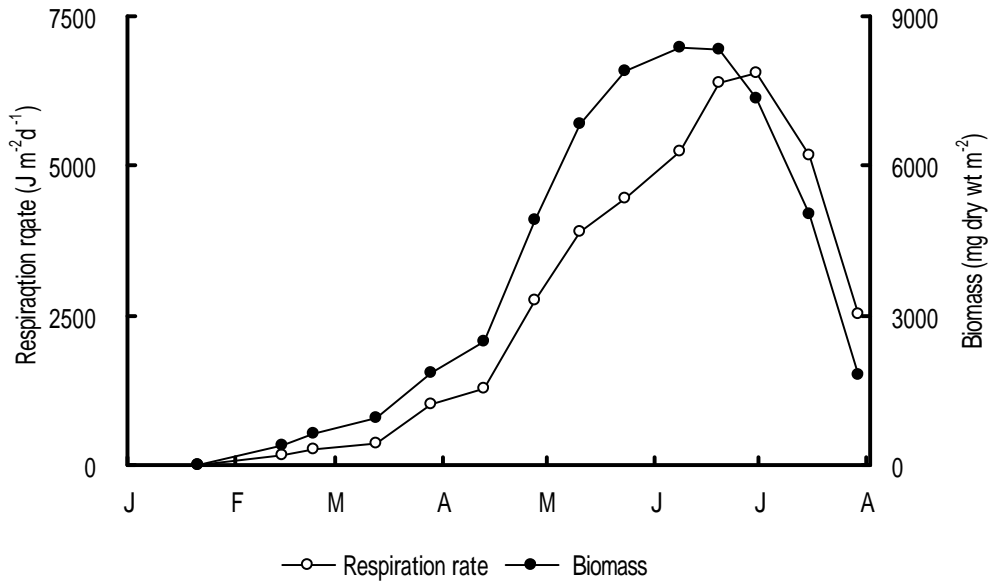
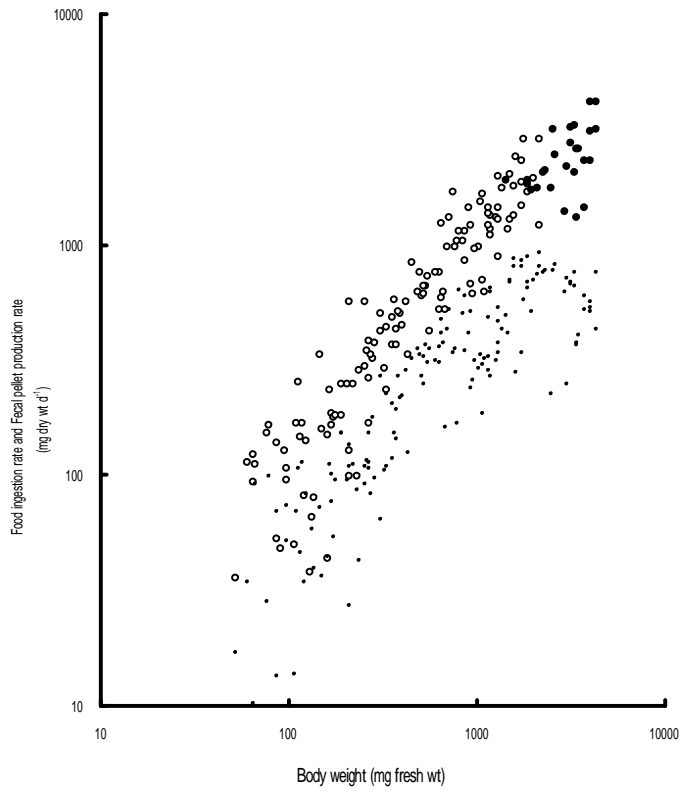
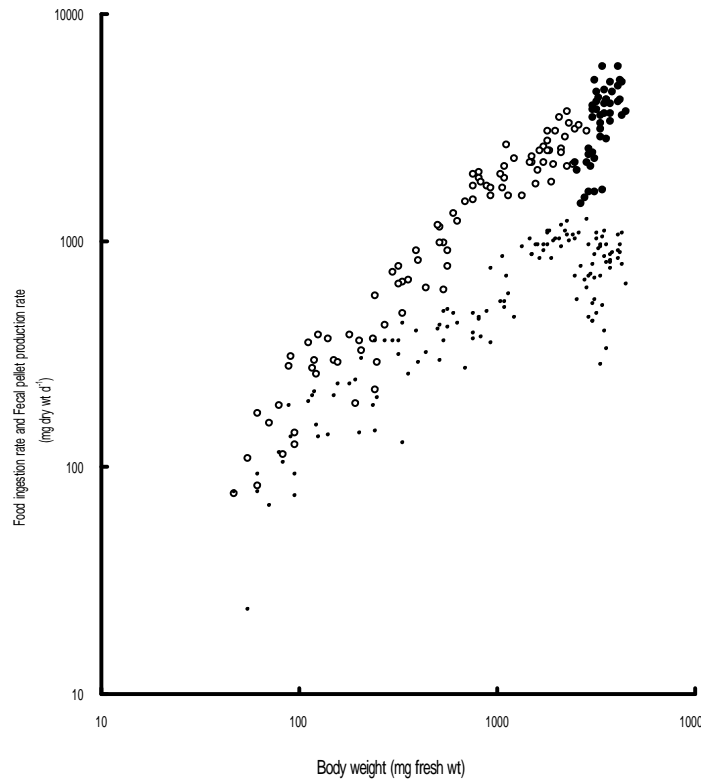

Fig. 3-4. Seasonal change in biomass, respiration, average body weight and number



at 15 .



at 20 .

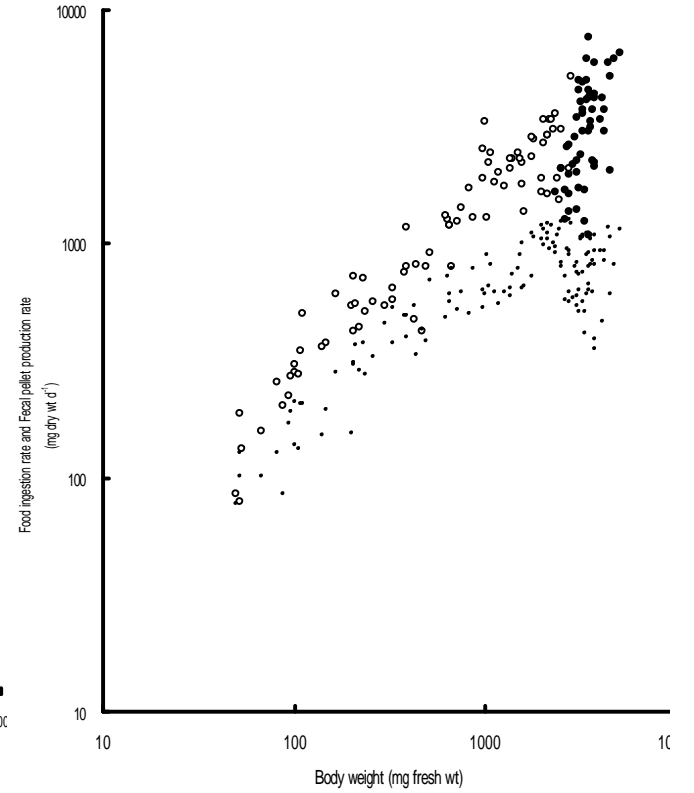

at 25 .

- fecal pellet production rate of immature worms
- food ingestion rate of immature worms
- fecal pellet production rate of mature worms
- food ingestion rate of mature worms

Fig. 4 Daily fecal pellet production rate and daily food ingestion rate of te worms

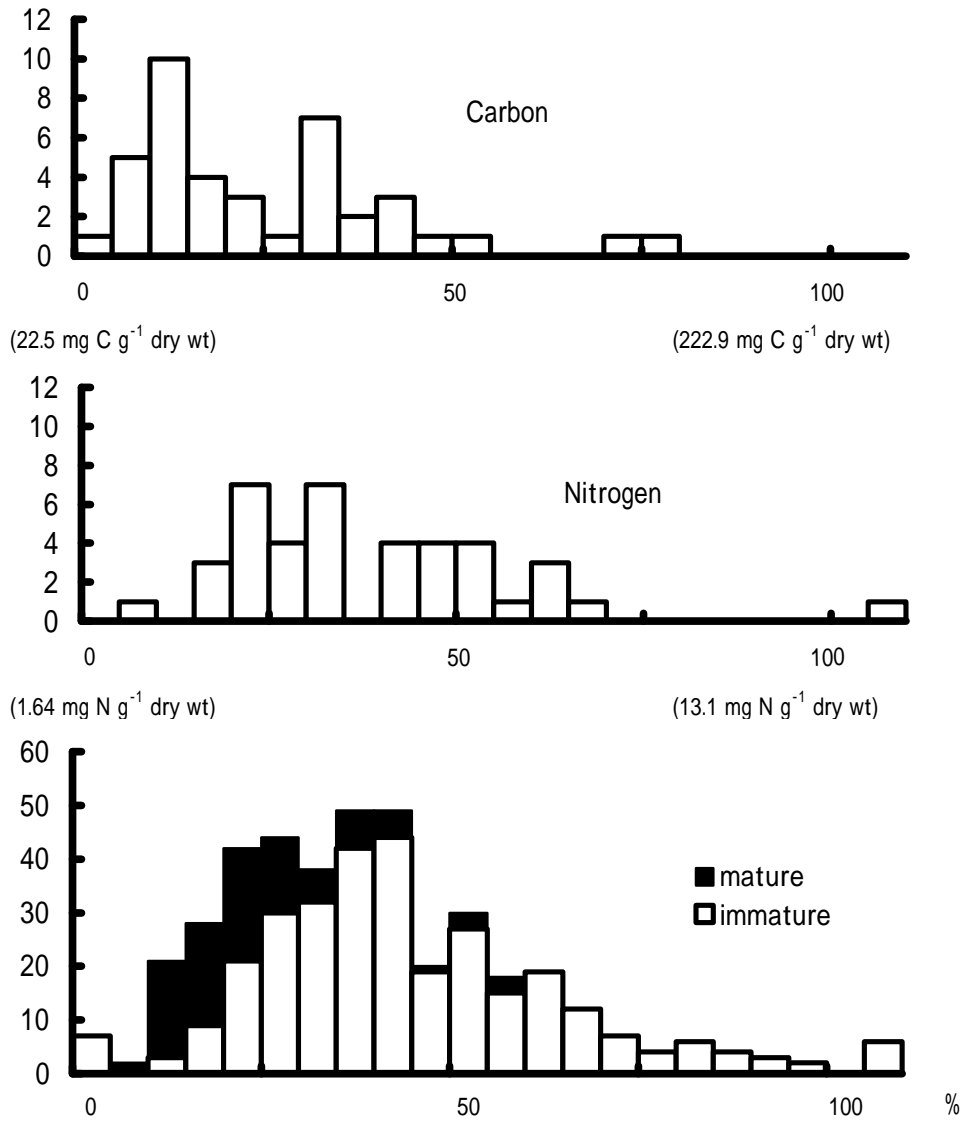

Fig.4-6. Nutrient contents of the materials in alimental canal of the pre-mature worms collected in field.

a, Carbon content; b, Nitrogen content; c, The ratio of food consumption to fecal pellet production, of the reared worms. In Lowest figure, the open area indicates the contribution by immature worms and the black area indicates the contribution by mature worms.

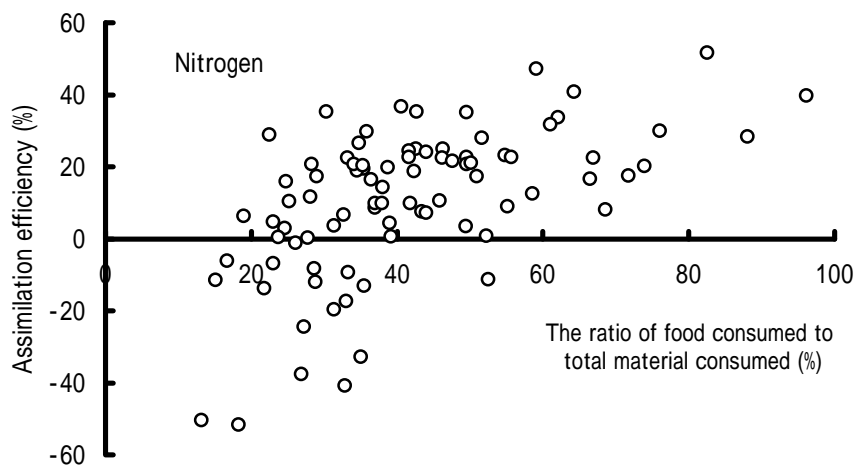
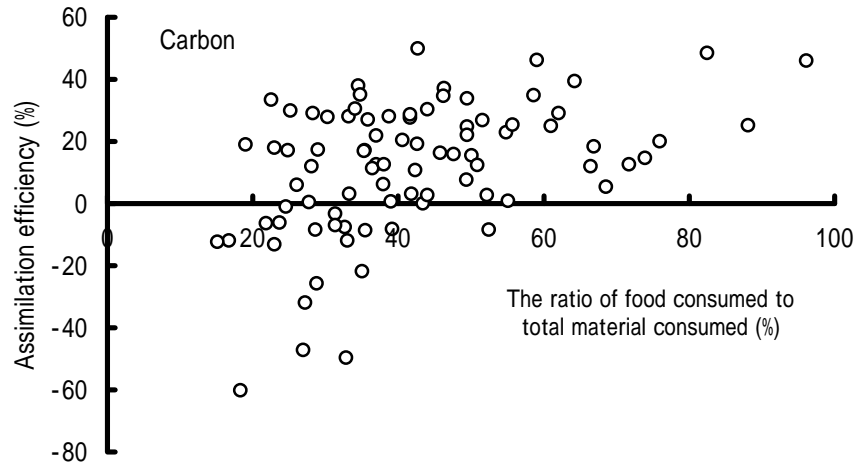

Fig. 5-2a. The relation between the assimilation efficiency and the ratio of food consumed to total material consumed. The assimilation efficiency in above figure was estimated from the data on Carbon content, and in below figure, on Nitrogen content.

Table 5-1 Assimilation efficiency of *Phererima* sp. (H-1)

		Efficiency (%)	<u>Food consumption</u> Pellet production (%)
Reared worms (A=C-F)	Carbon	8.124	35.5
	Nitrogen	7.392	
Reared worms (A=P+R)	25	2.31	35.5
	20	1.98	
	15	2.22	
Field Population	Carbon	1.895	24.77
	Nitrogen	9.559	38.86

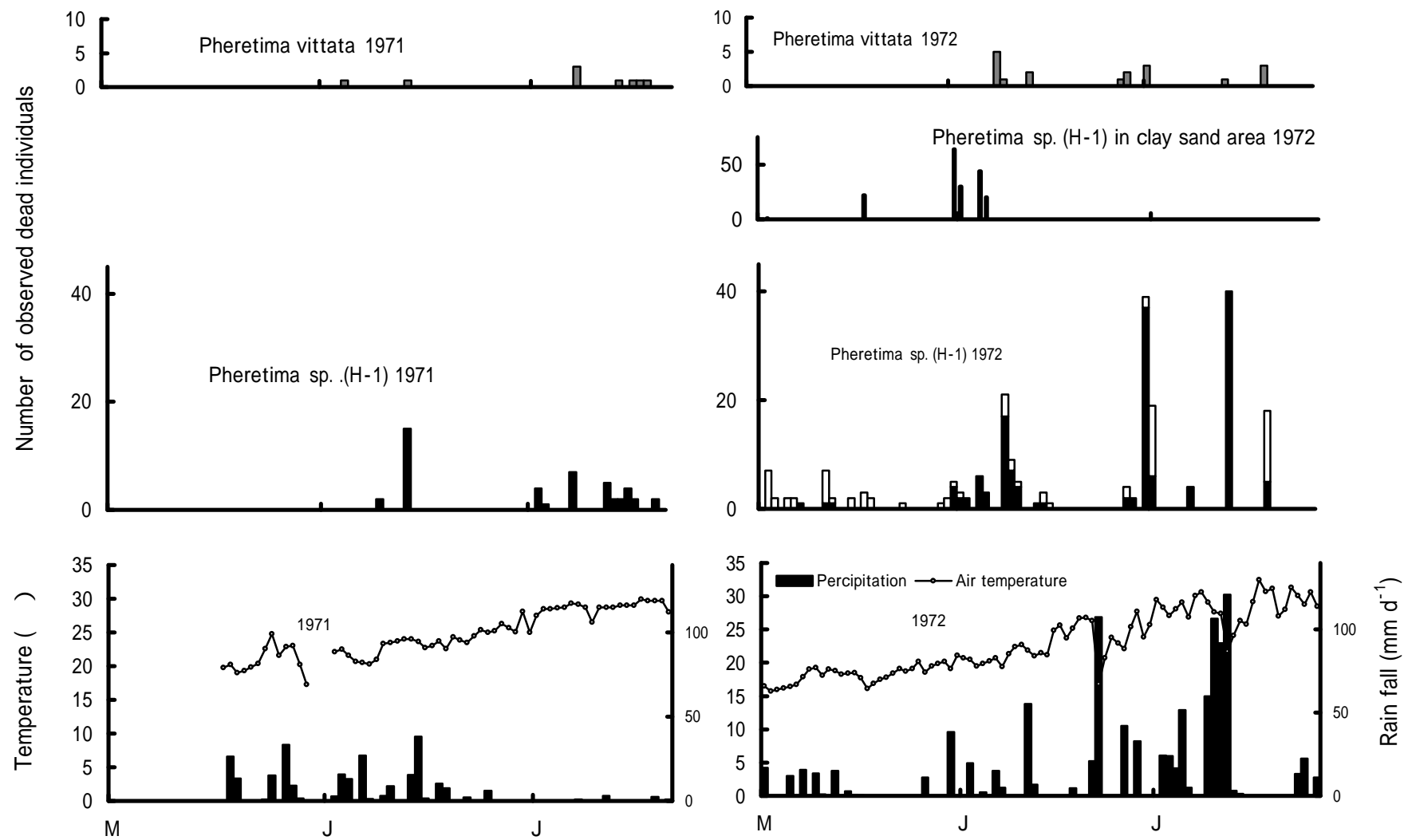

Fig. 7-3. Daily change in number of observed dead individuals.

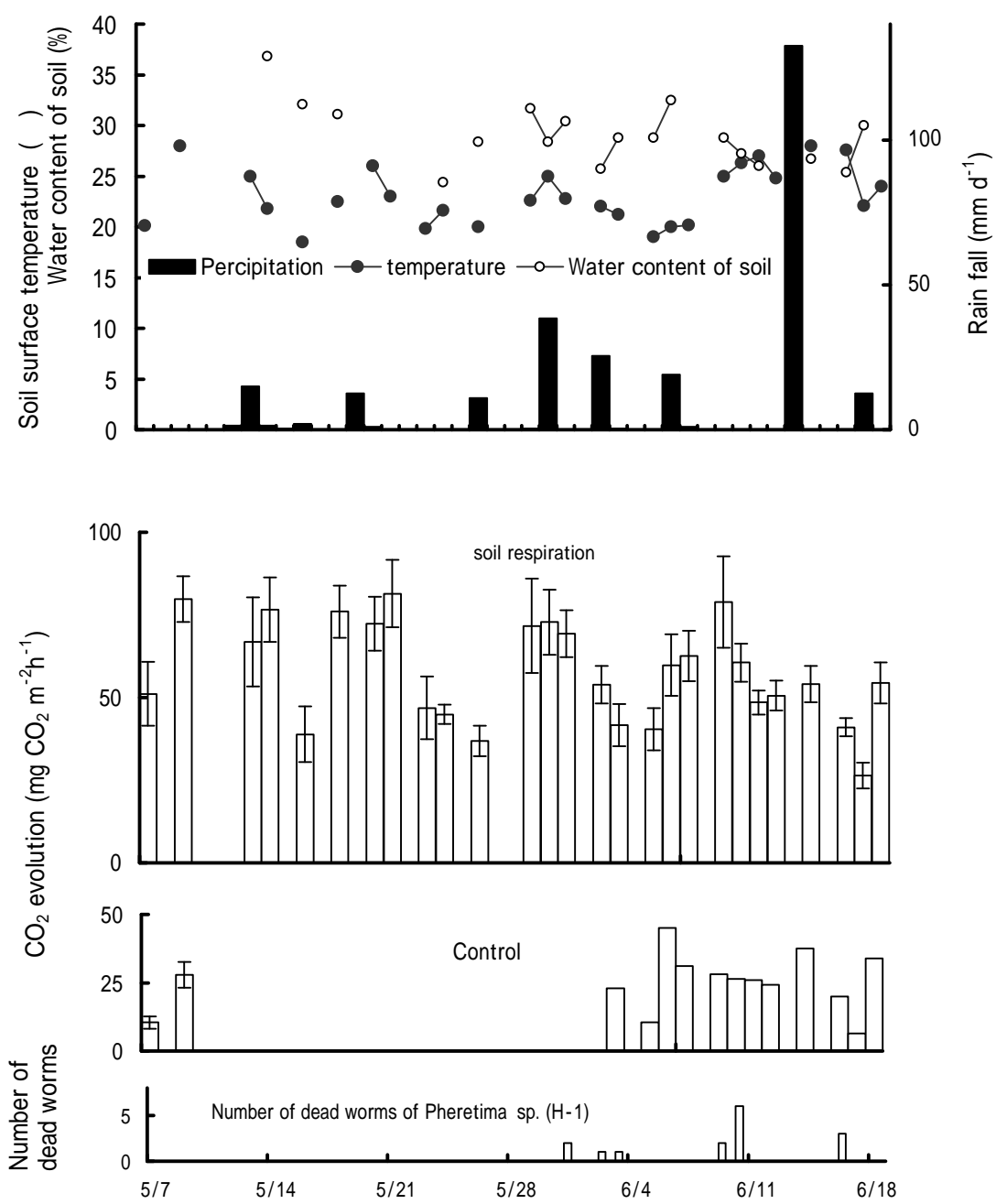

Fig7-4 Daily fluctuation of CO<sub>2</sub> evolution.

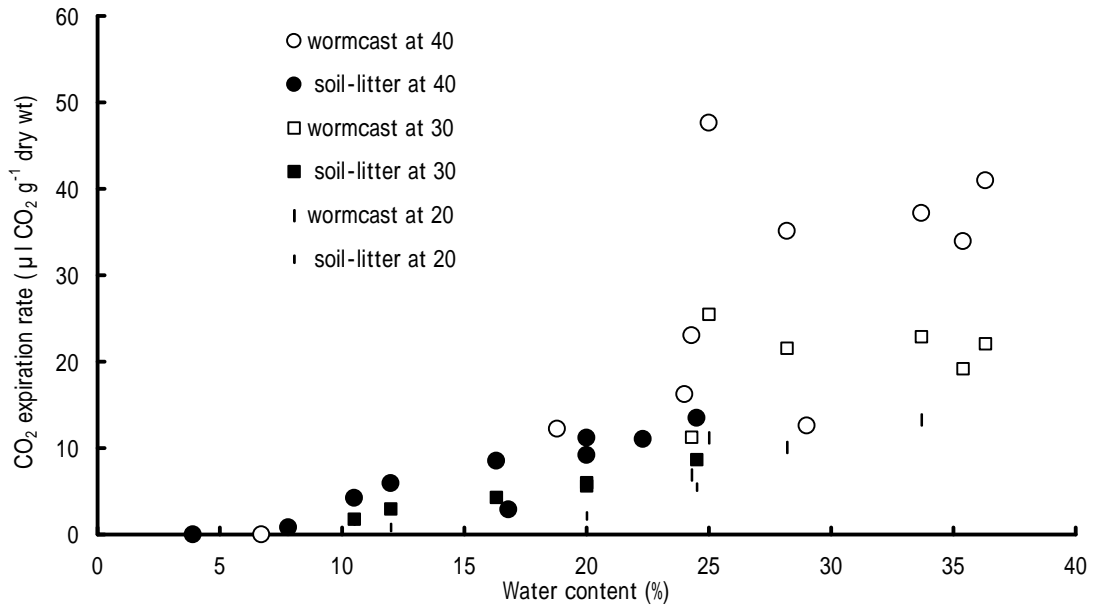

Fig. 7-5. The relation between soil respiration rate and the water content of the materials.

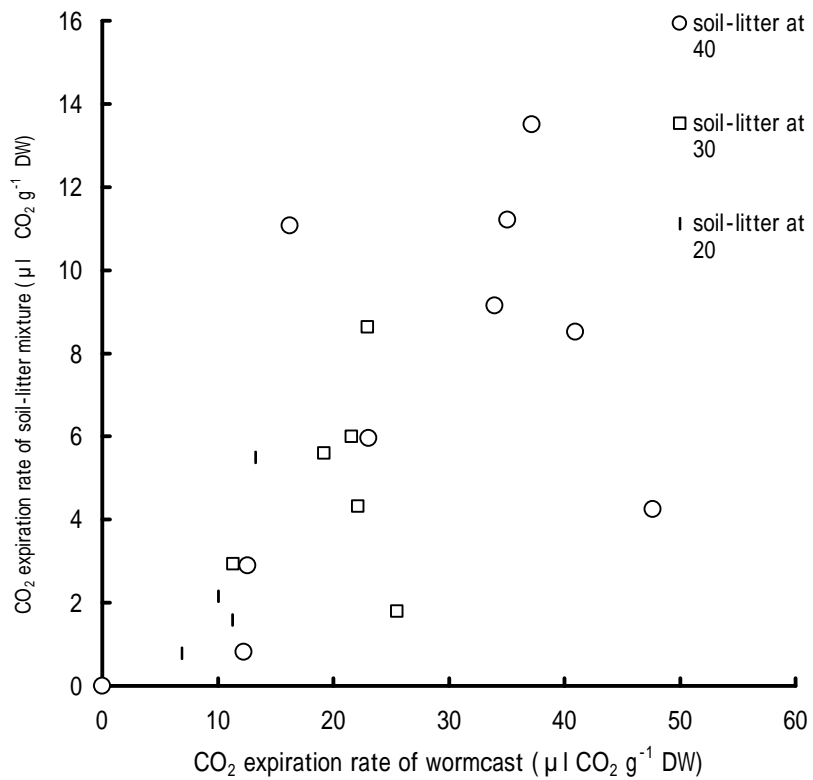

Fig. 7-6. The relation in soil respiration rate between the worm cast and the soil

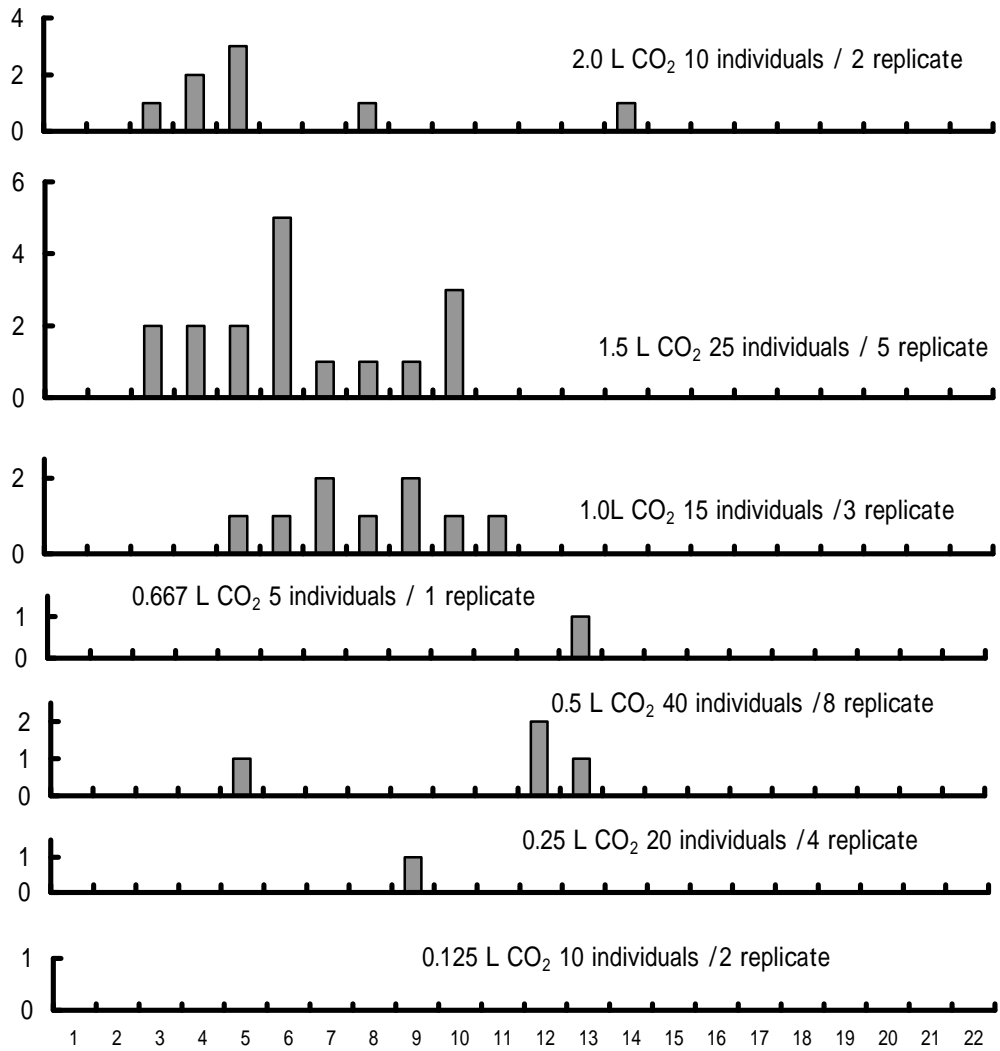

Fig. 7-7a Number of earthworm showing the rashing out behavior to various concentration of Carbon dioxide gases.

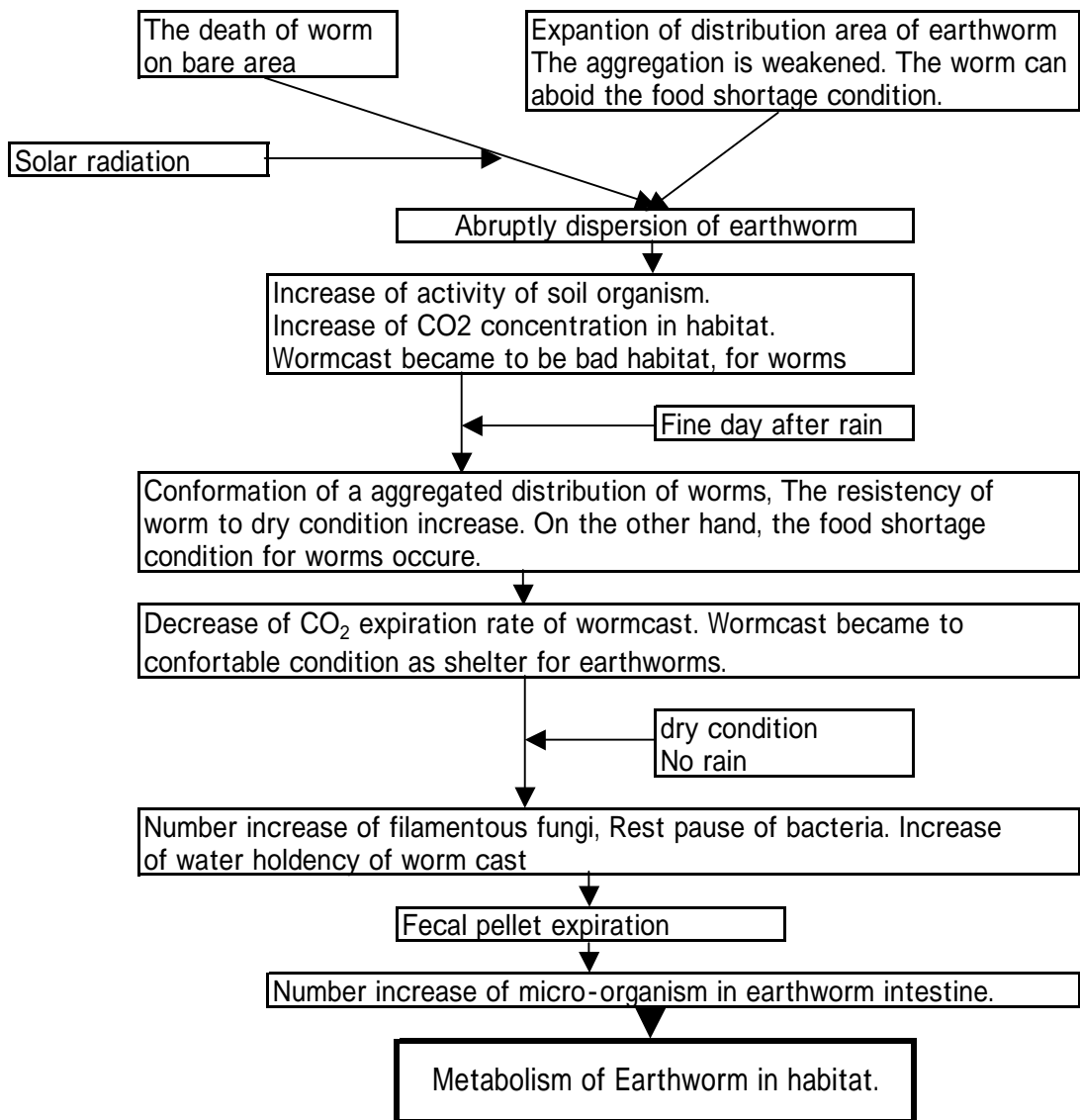

Fig7-9 Population meaning of the simultaneously death of earthworm;  
Amyntas sp. (H-1) on fine days after rain

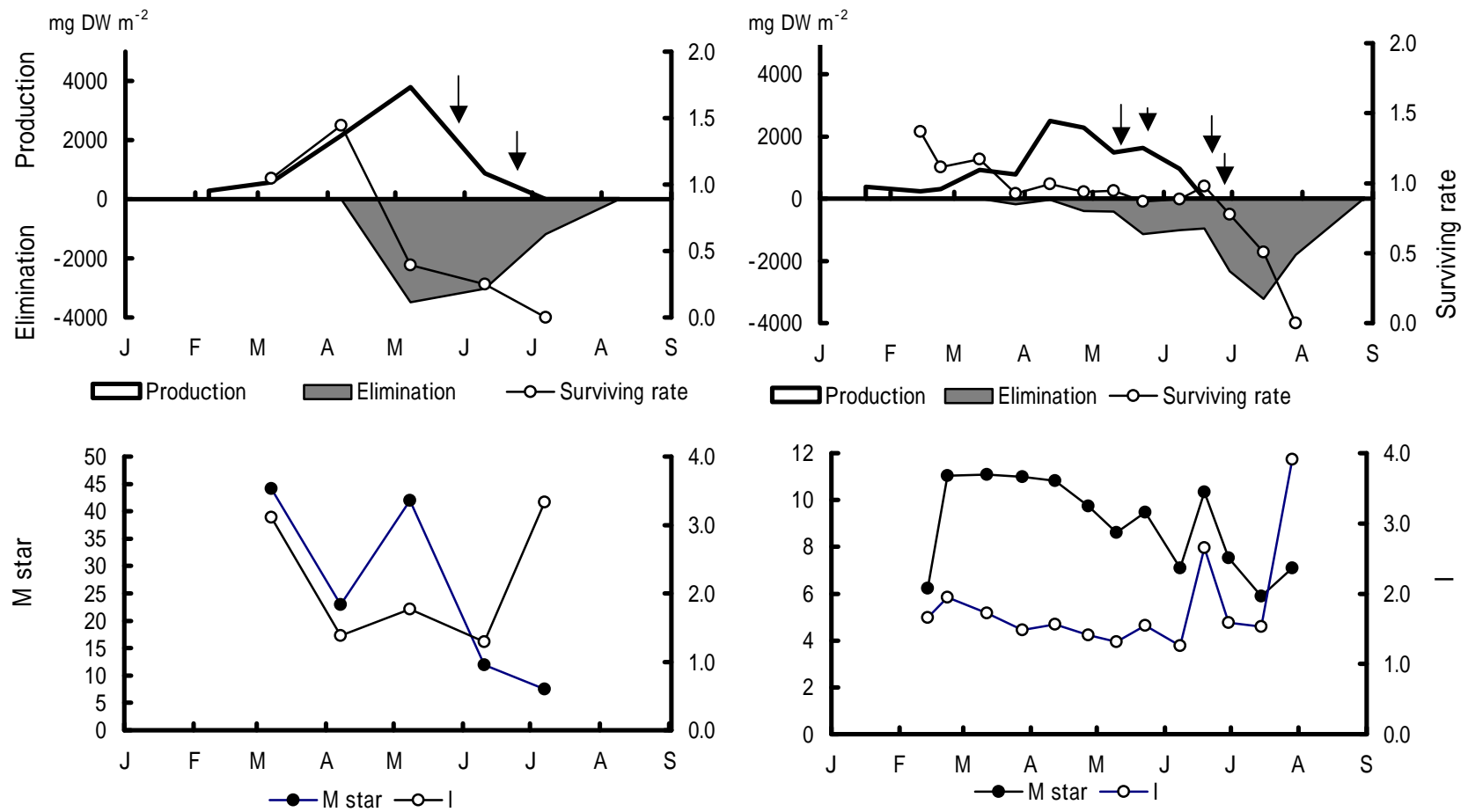

Fig. 8-2. Seasonal change in the distribution pattern of individuals of field population.

In upper figure, the open circle indicate the surviving rate and open area indicate the production and black area indicate the elimination, of the population and the arrow line indicate the conspicuous outbreak of the simultaneously death of earthworm on fine days after rain. In lower figure, open circles indicate the value of I and black circles indicate the value of mean crowding.

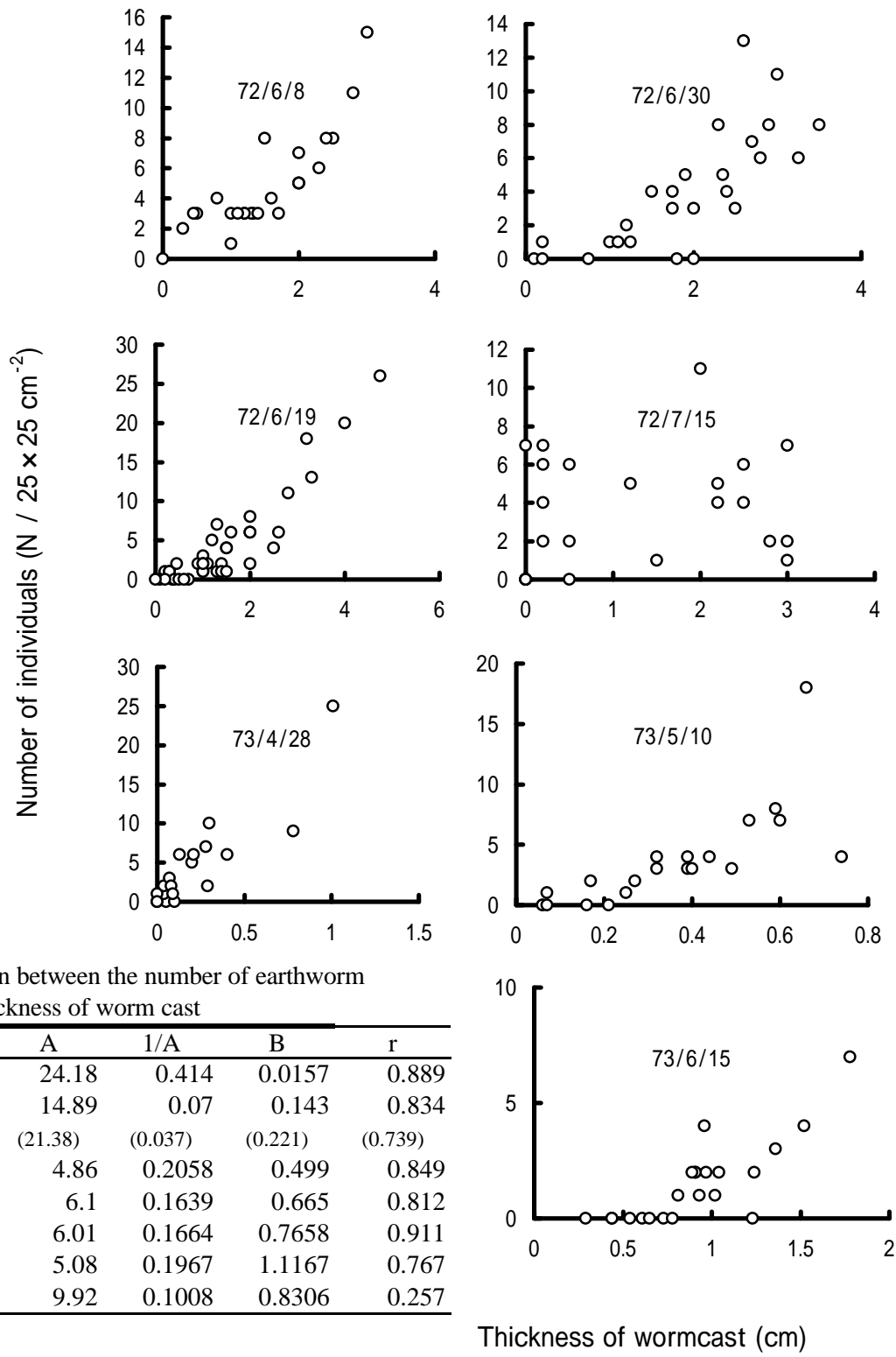

Fig. 8-3. The relation ship between number of individual and thickness of wormcast.

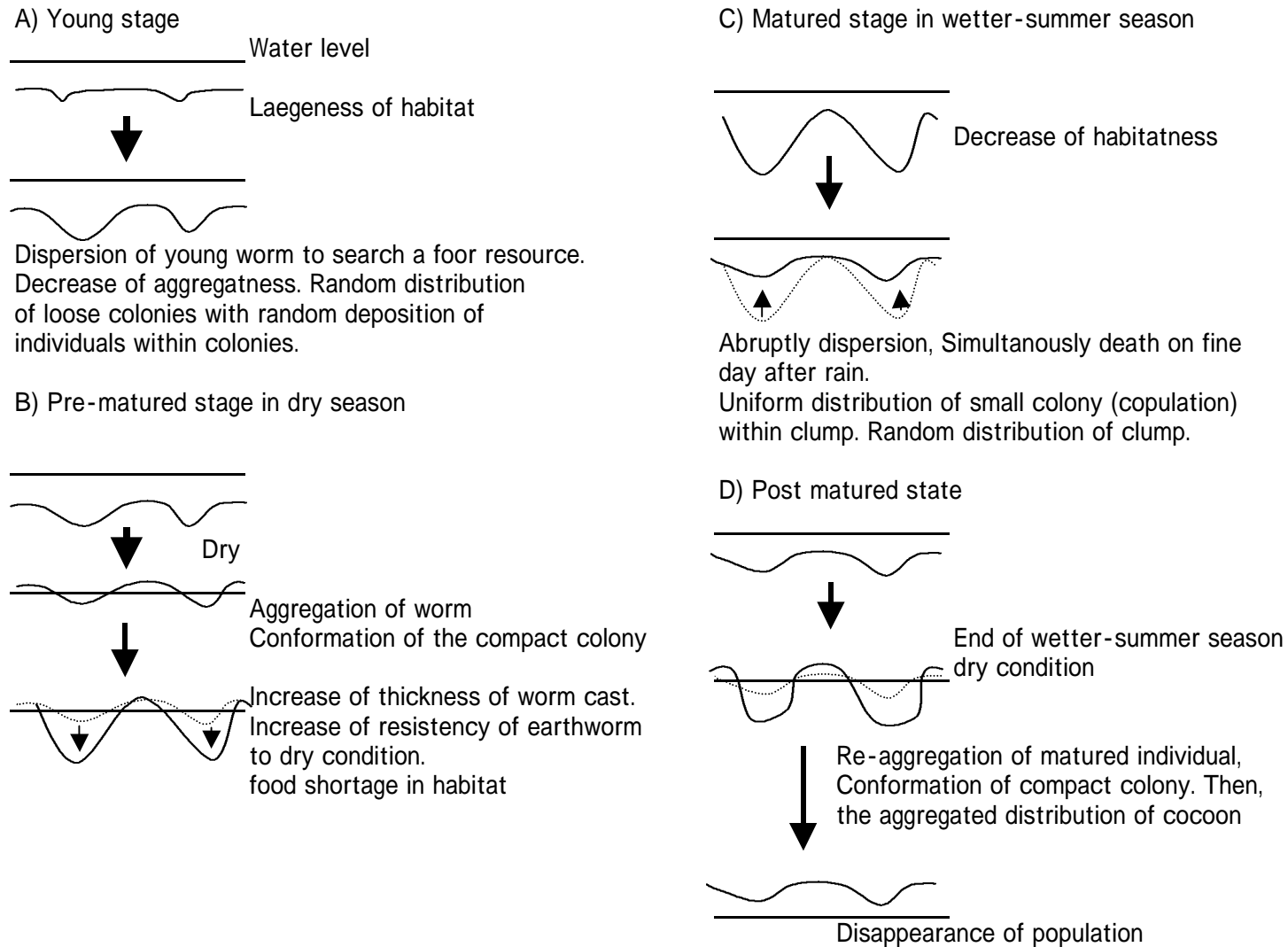

Fig. 8-8. The structure of habitat and the distribution pattern of earthworm ; *Amynthus* sp. (H-1).

**Table 11-1 Bio-economic life table of *Pheretima* sp. (H-1) in area D 1972**

Date	N	B	B.W	P	E	F.R A.H	F.R A.V	F.C A.H	F.C A.V	L-C	R.W	* m/m	* m	A
Jan.	0.0	0.0	0.0			0.0	0.0	0.0	0.0	1176.5				
Feb.14	60.8	379.6	6.2	15.8		0.2	0.0	0.1	0.0	1175.3		1.7	6.2	
Feb.23	83.2	619.2	7.4	26.6		0.4	0.0	0.3	0.0	1170.2		1.9	11.0	
Mar.12	92.8	933.7	10.1	18.5		0.6	0.1	0.4	0.1	1162.2		1.7	11.1	
Mar.28	108.8	1850.9	17.0	57.3		3.8	0.3	2.6	0.3	1118.7		1.5	11.0	
Apr.12	100.5	2457.3	24.5	51.9	11.5	5.9	0.5	4.1	0.5	1049.7		1.6	10.8	
Apr.27	99.8	4924.5	49.3	166.2	1.7	19.3	1.5	13.4	1.4	827.7		1.4	9.7	24.2
May 10	93.4	6821.0	73.0	152.5	26.1	30.7	3.1	21.4	2.8	531.3		1.3	8.6	14.9
May 23	88.3	7892.4	89.4	114.2	31.9	33.0	6.4	23.0	5.9	68.4		1.5	9.5	
Jun. 8	76.8	8378.2	109.1	101.7	71.3	32.8	5.1	22.9	4.7	0.0	15.2	1.3	7.1	4.9
Jun.19	68.0	8326.0	122.4	87.9	92.6	27.0	4.9	18.9	4.5		15.2	2.7	10.4	6.01(6.10)
Jun.30	66.6	7368.0	110.6		87.2	25.6	5.6	17.9	5.1		15.2	1.6	7.5	5.1
Jul.15	51.8	5028.5	97.1		156.0	19.3	8.6	13.4	7.9		15.2	1.5	5.9	9.9
Jul.29	26.2	1803.5	68.8		232.5	9.1	4.9	6.3	4.5		15.2	3.9	7.1	
Aug.28	0.0	0.0	0.0		60.1	0.0	0.0	0.0	0.0		15.2			

N:density (N m<sup>-2</sup>), B:Biomass (dry wt m<sup>-2</sup>), B.W:Body dry weight of individual, P:Production (dry wt w<sup>-2</sup>), E:Elimination (dry wt w<sup>-2</sup>)

F.R A.H:Litter requirement of *Amyntas* sp.(H-1), F.R A.V:Litter requirement of *Amyntas vittatus*,

F.C A.H: Litter consumption of *Amyntas* sp. (H-1), F.C.A.V: Litter consumption of *Amyntas vittatus*

L-C:Litter supply - Litter consumption, R.W: Resource supply from wormcast, (m/m, m, A: The degree of Aggregation of individuals, see Chapter 8)

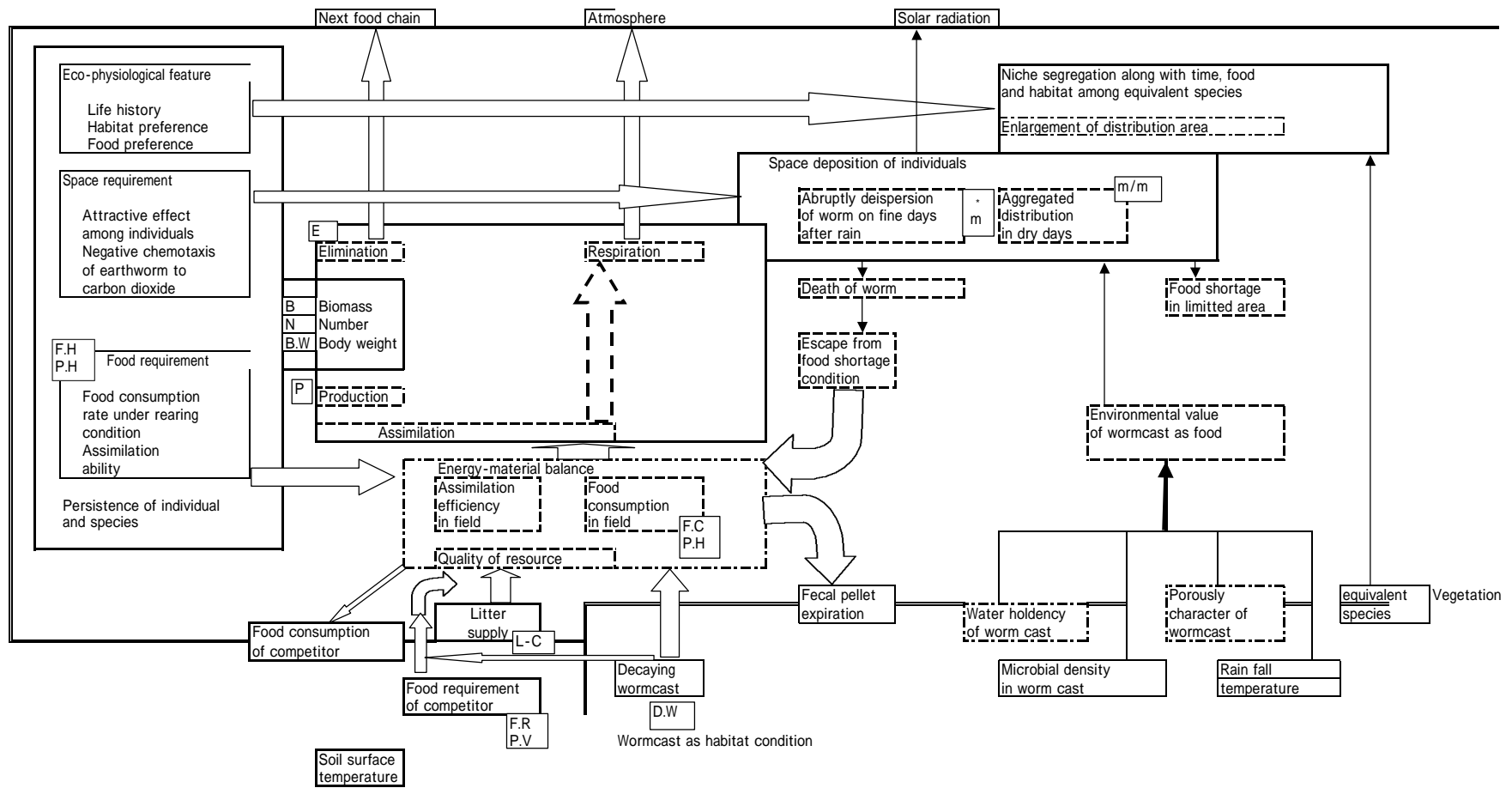

**Fig. 11-1. Inter relationship between environment and earthworm**

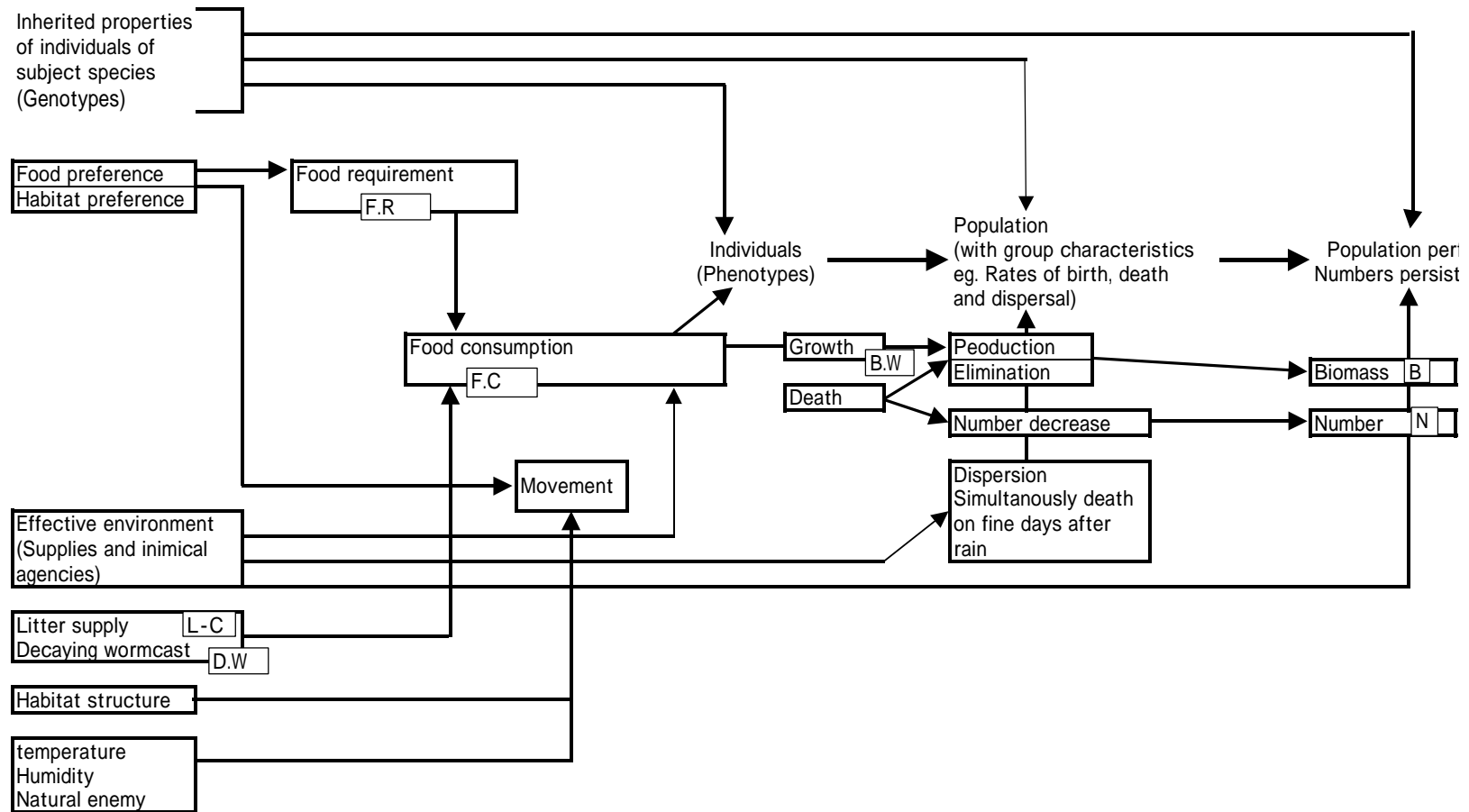

**Fig. 11-2. The components of earthworms life system**

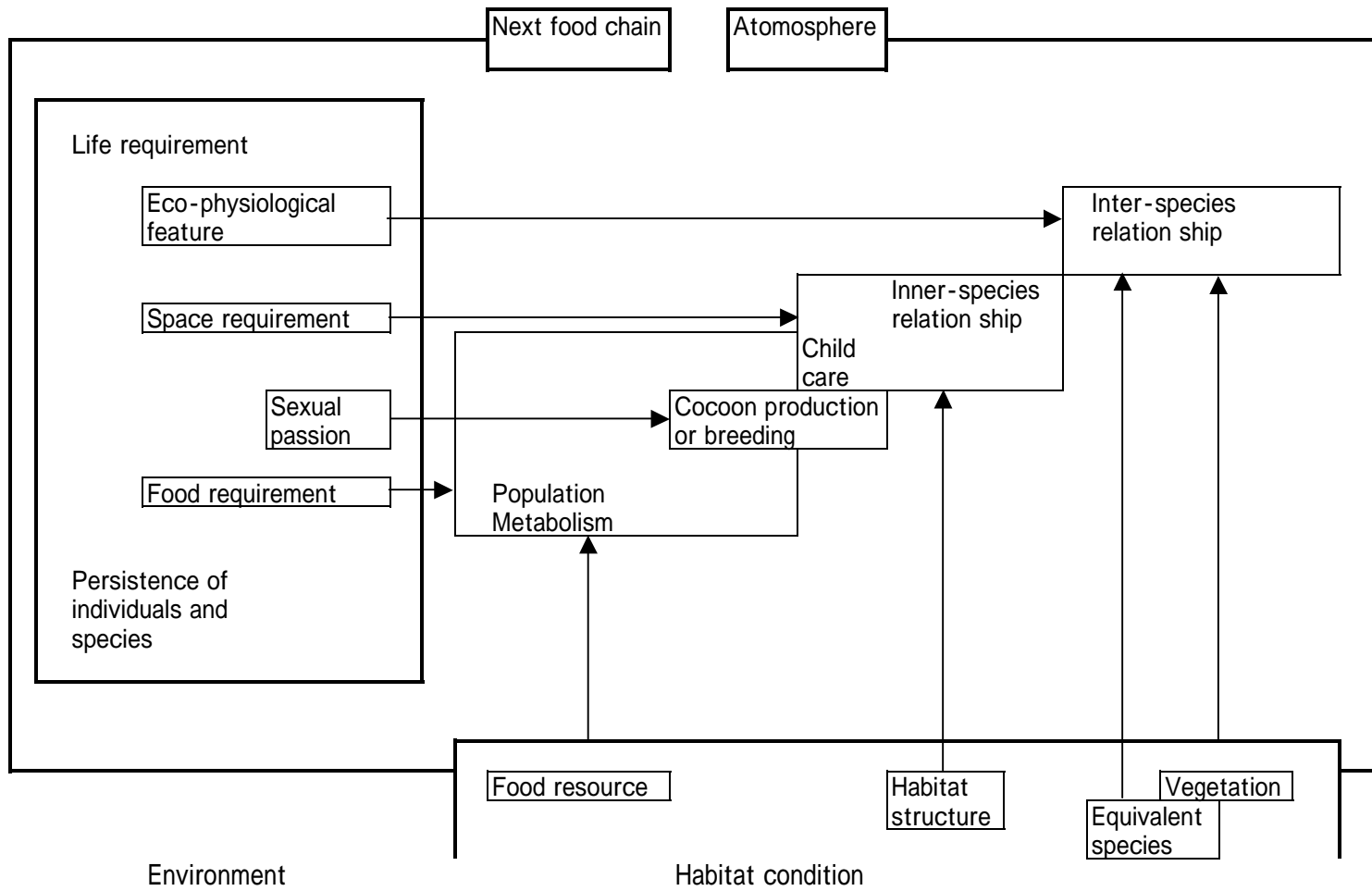

Fig. 11-3. Inter relationship between environment and animals.